

C ↑

C ( 1 : 2 )

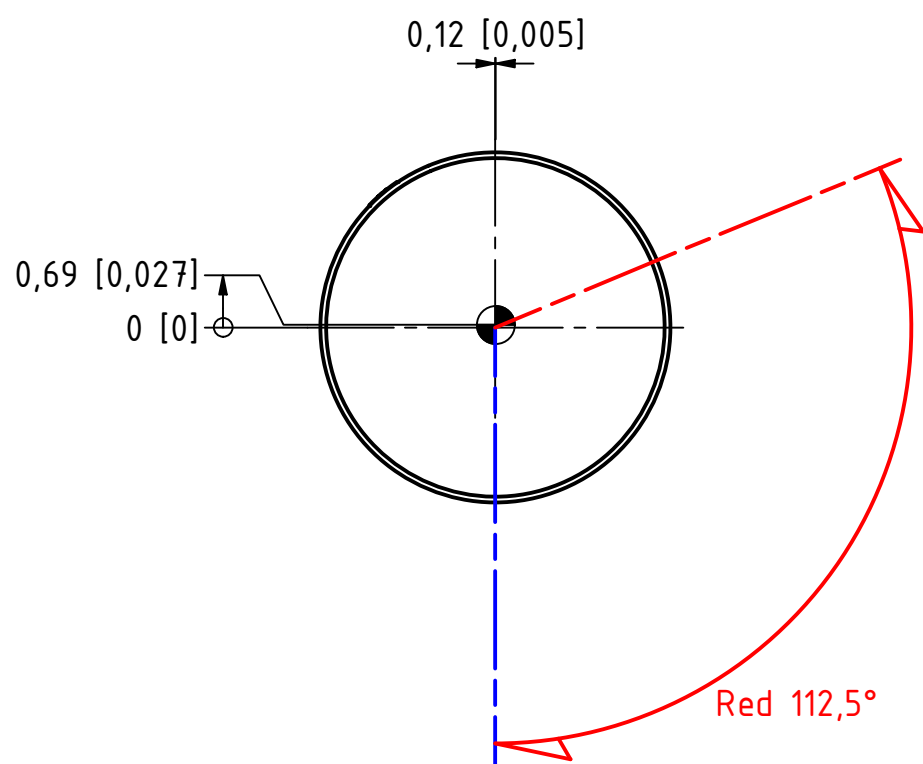
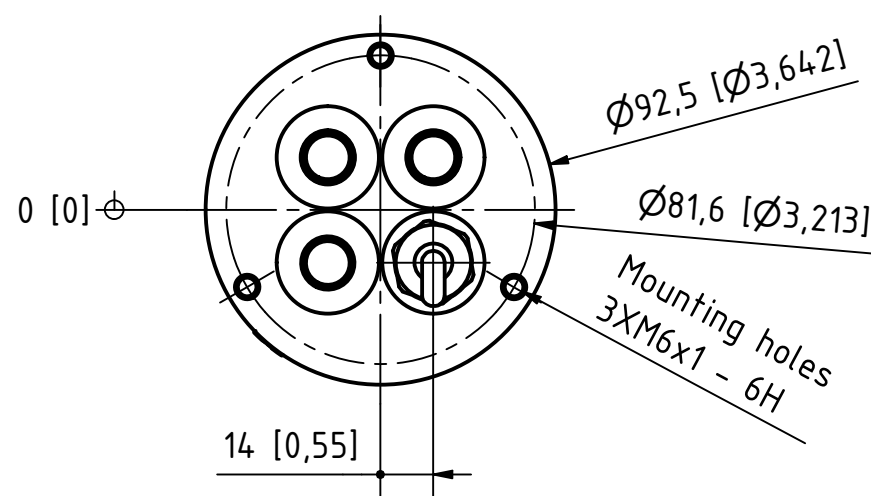

Dimensions : Millimetres [Inches]  
 Estimated weight: 0,8 kg (1,8 lbs)

TITLE: <b>301-009-WH-UL</b> 2nm Port, white ceramic coated, UL On a 400-035 Promount base, Cable Down					
DRAWING No.: <b>301-009-WH-UL</b>				Sheet No.: <b>1</b>	DRAWN BY: <b>LSA</b>
SCALE: <b>1 : 2</b>	SIZE: <b>A3</b>	REV. NO.:	TOLERANCES: <b>DS/ISO 2768-f</b>	REVIEWED BY:	CREATION DATE: <b>08-06-2023</b>
MATERIAL DESCRIPTION: <b>Alu. EN6082, Acrylic</b>					
<small>(25µ) Silver anodized according to EN ISO 7599          (50µ) Black anodized according to MIL-A 8625F</small>					
<small>This Drawing, and the information within, is the property of Lopolight ApS and may not be used in any form without express permission there from. Lopolight reserves the right to change this drawing and assumes no liability for the information communicated herein. Use of dimensions and other information in this drawing is at the users own risk.</small>					



Lopolight ApS  
 Bakkegaardsvej 513  
 DK-3050, Humlebaek  
 Denmark  
 www.lopolight.com

Tel:(+45) 32 48 50 30  
 info@lopolight.com



A B C D E F G H I J

1  
2  
3  
4  
5  
6  
7  
8

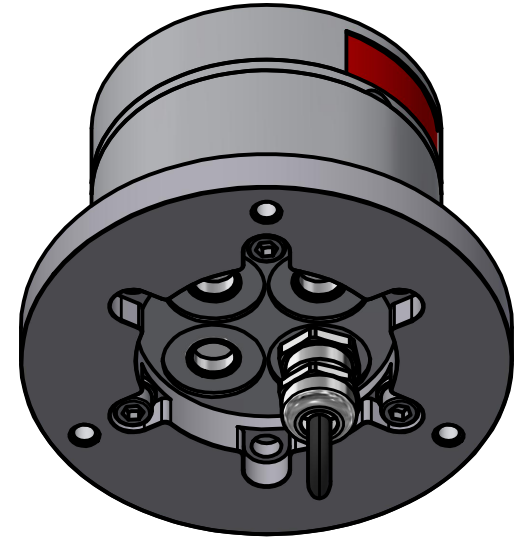
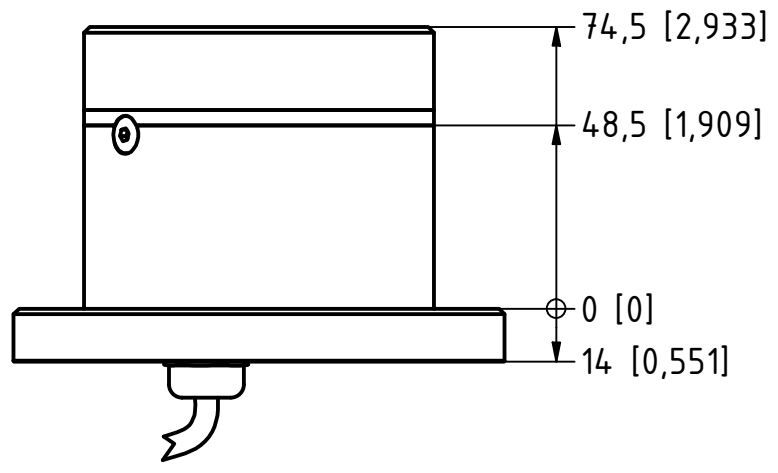
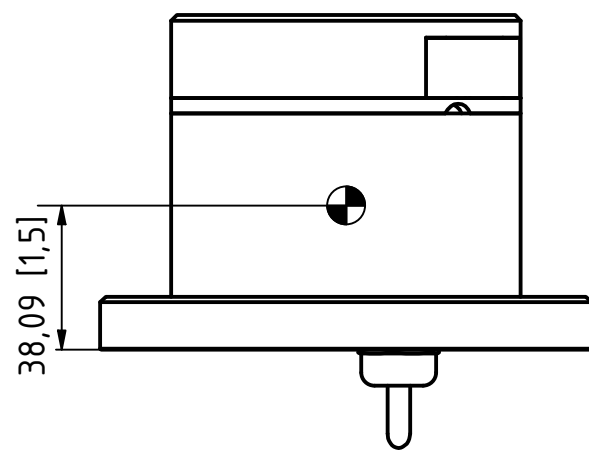
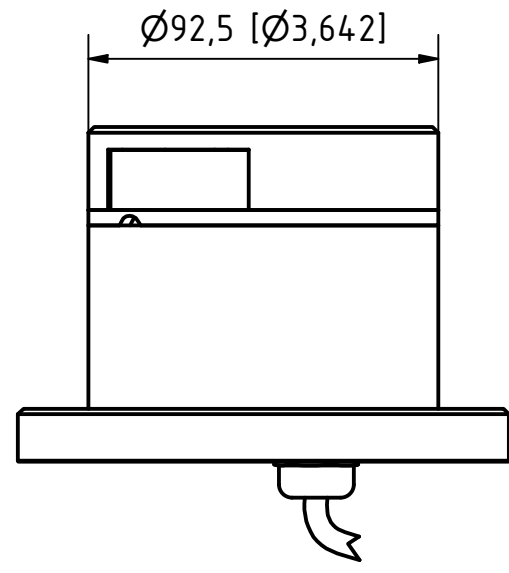

D ↑

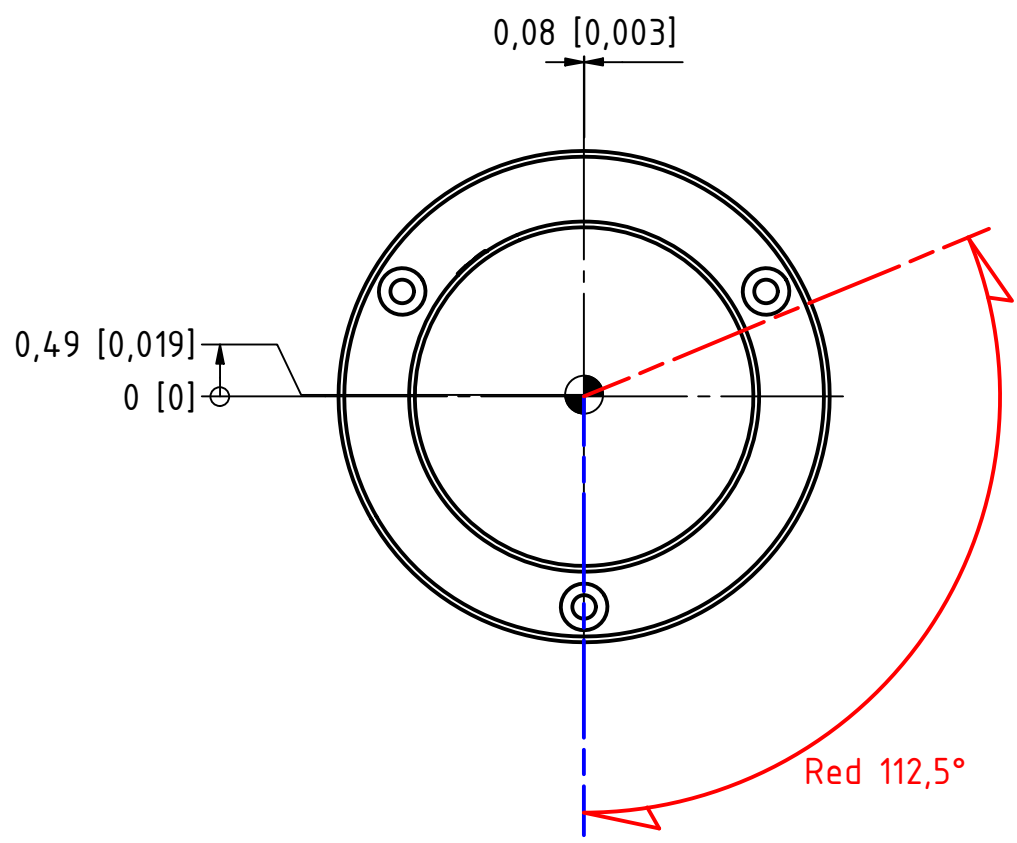
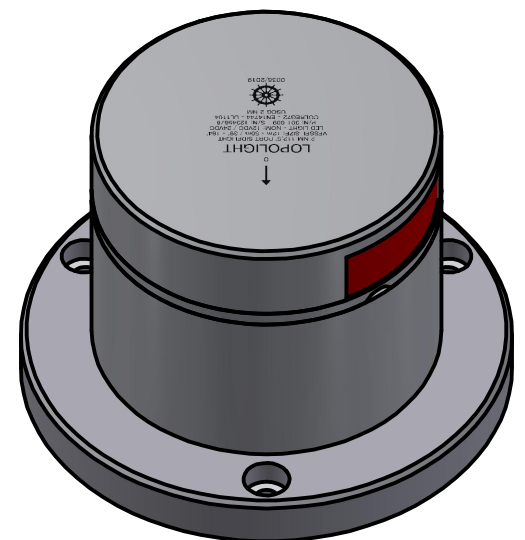
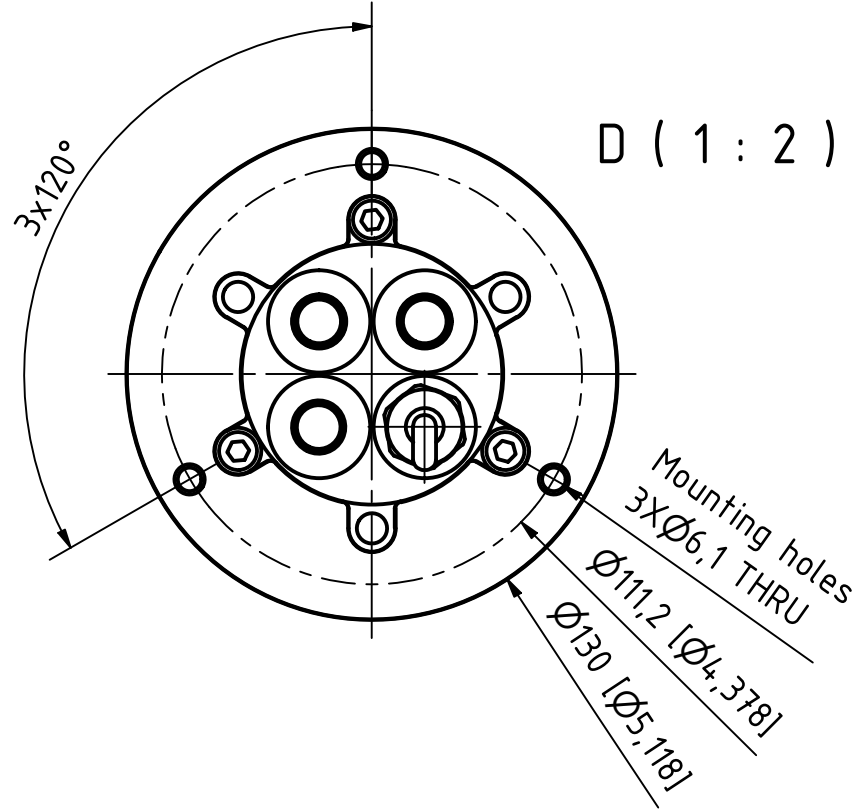

Dimensions : Millimetres [Inches]  
Estimated weight: 1,1 kg (2,5 lbs)

TITLE: 301-009-WH-UL 2nm Port, white ceramic coated, UL On a 400-035 Promount base and 400-401 circular aluminium baseplate					
DRAWING No.: 301-009-WH-UL			Sheet No.: 2	DRAWN BY: LSA	
SCALE: 1 : 2	SIZE: A3	REV. NO.:	TOLERANCES: DS/ISO 2768-f	REVIEWED BY:	CREATION DATE: 08-06-2023
MATERIAL DESCRIPTION: Alu. EN6082, Acrylic					
<small>(25µ) Silver anodized according to EN ISO 7599 (50µ) Black anodized according to MIL-A 8625F</small>					

This Drawing, and the information within, is the property of Lopolight ApS and may not be used in any form without express permission there from. Lopolight reserves the right to change this drawing and assumes no liability for the information communicated herein. Use of dimensions and other information in this drawing is at the users own risk.

**LOPOLIGHT**  
Lopolight ApS  
Bakkegaardsvej 513  
DK-3050, Humlebaek  
Denmark  
www.lopolight.com

Tel:(+45) 32 48 50 30  
info@lopolight.com

A B C D E F G H I J

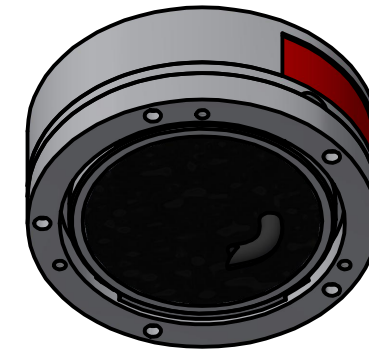
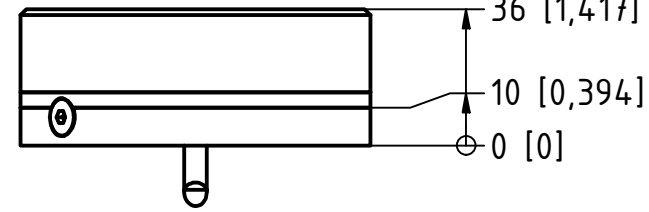
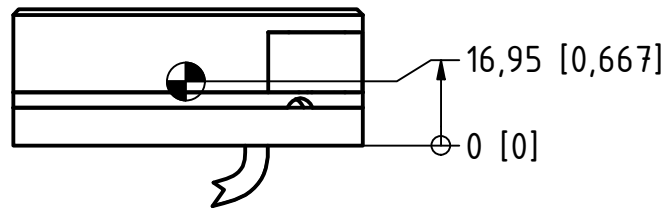
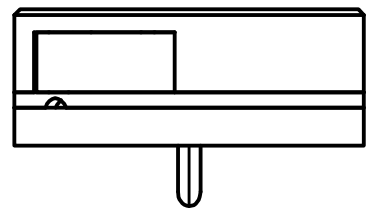

F ↑

F ( 1 : 2 )

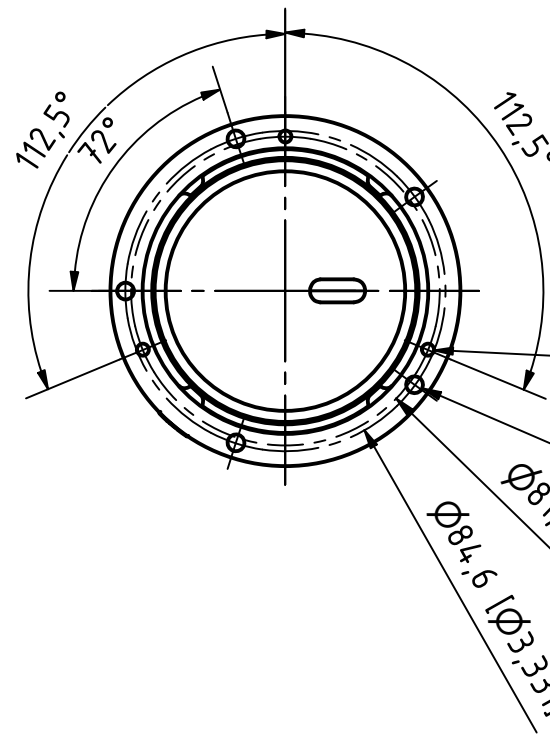

Mounting holes (Mount from underside)  
3XM4x0.7 THRU

Mounting holes (Mount from top)  
5x Countersunk for 4 mm  
cylinderhead (DIN 912/ISO4762)

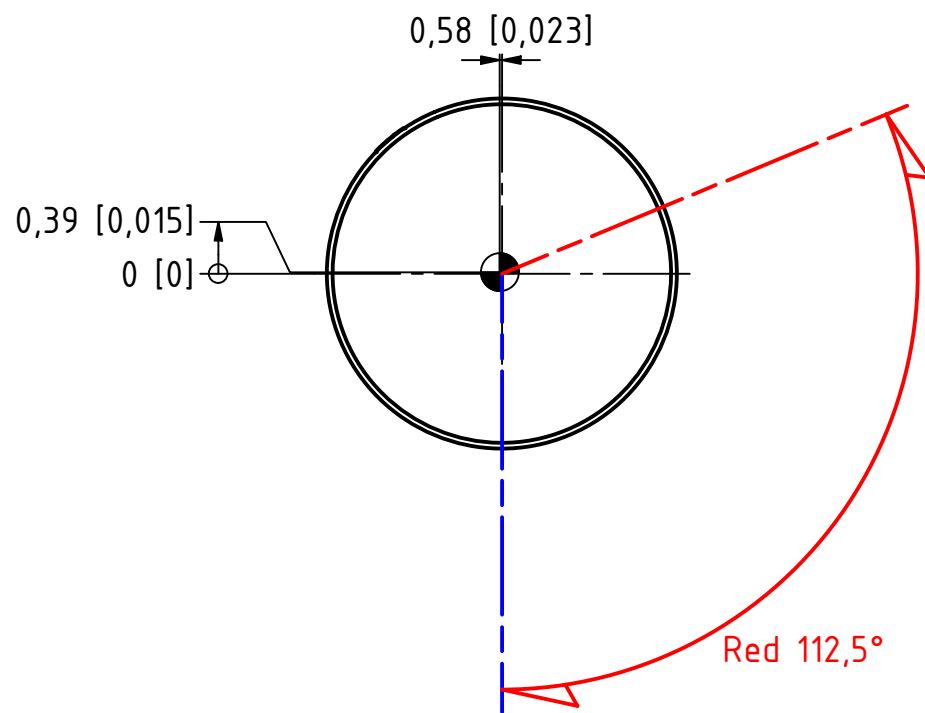

Red 112,5°

Dimensions : Millimetres [Inches]  
Estimated weight: 0,5 kg (1 lbs)

TITLE: 301-009-WH-UL 2nm Port, white ceramic coated, UL On a 400-036 Ultra Low profile base					
DRAWING No.: 301-009-WH-UL				Sheet No.: 3	DRAWN BY: LSA
SCALE: 1 : 2	SIZE: A3	REV. NO.:	TOLERANCES: DS/ISO 2768-f	REVIEWED BY:	CREATION DATE: 08-06-2023
MATERIAL DESCRIPTION: Atu. EN6082, Acrylic					
(25µ) Silver anodized according to EN ISO 7599 (50µ) Black anodized according to MIL-A 8625F					
This Drawing, and the information within, is the property of Lopolight ApS and may not be used in any form without express permission there from. Lopolight reserves the right to change this drawing and assumes no liability for the information communicated herein. Use of dimensions and other information in this drawing is at the users own risk.					



Lopolight ApS  
Bakkegaardsvej 513  
DK-3050, Humlebaek  
Denmark  
www.lopolight.com

Tel:(+45) 32 48 50 30  
info@lopolight.com

