



Commercial Equipment Guide
Anchor Winches and Windlasses



Since 1968. Built to last.

Located deep in the wild Southern Ocean, Tasmania's harsh and challenging marine environment means that anything made here must be made well. And it must be made to last.

It's here that for over 50 years Muir has been designing and manufacturing anchoring systems and mooring equipment that have withstood the test of time, and the test of nature.

With a comprehensive quality assurance system to ensure durability and safety, our anchoring systems, mooring and deck equipment are respected for their quality and performance.

From a 5-metre vessel to the world's largest mega yachts. Muir has become a dominant force in anchoring and mooring technology, recognised today as the anchoring system choice for a large variety and size of luxury motor and sail yachts. Muir design and manufacture one of the largest ranges of anchoring and mooring systems for vessels up to 150 metres.

Muir have designed and produced anchoring and mooring equipment having set industry standards and benchmarks over many years. Continued investment

in research and development, design and innovation, keeps Muir at the forefront of the yachting industry. Muir surpass or meet the world's most stringent classification requirements including ABS.

In addition to mega and premium yacht equipment, Muir manufacture a range of anchoring and mooring equipment in all configurations, including drum winches for work boats, fast ferries, naval and defence vessels up to 160 metres and up to 15,000kg pull. With unrelenting dedication to total quality in design and manufacture and a desire to provide perfection for our clients, Muir is the preferred choice for your anchoring and mooring system solutions.

Muir has a national network of experienced sales managers, combined with trusted international strategic partners and distribution network. This ensures that Muir is led by knowledge to deliver quality to you, no matter the size of your vessel.



Contents

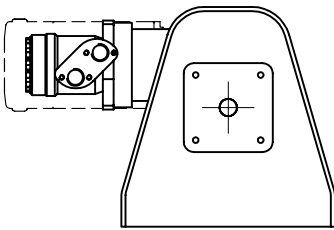
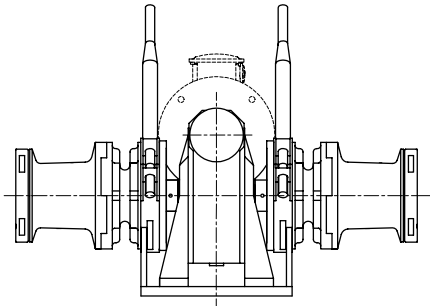
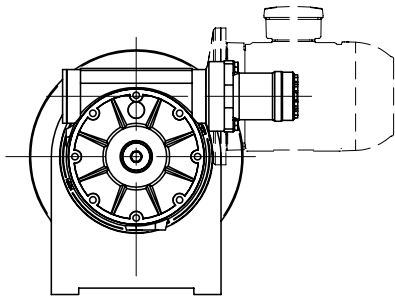

Technical Information **4**

Certified and Accredited Quality **5**

Drum Winches, Windlasses and Fishing Winches

SD Series **8**

Horizontal 'SGC' Windlasses

SGC Series **9**

Ramp & General Purpose Winches

RW Series **10**

Capstans and Windlasses

Docking Capstans **11**

Vertical Windlasses **12**

Horizontal Windlasses **13**

Gunwhale Hauler Capstan **14**

Chain Stoppers, Compressors and Devil's Claws

Chain Stoppers **15**

Chain Stopper Devil's Claws **15**

Chain Compressors **16**

Alloy Hatches **17**

Anchoring System Accessories **19**





Muir offers a comprehensive range of commercial equipment for patrol boats, work boats, fishing vessels and high speed ferries.

With an extensive history in marine engineering, Muir's Commercial equipment incorporates the vast knowledge and experience acquired over the past 45 years. Muir's range of commercial equipment is designed and manufactured to meet the most testing conditions. Function and reliability are foremost with the manufacture of Muir's Commercial range.

Muir's reputation for quality products extends across a full range of Commercial vessels Worldwide.

Equipment constructed in steel or light weight alloy for the high speed ferry operations reduce build weights by up to 35%. Muir can supply gear for vessels up to 150 metres in length.

A comprehensive range of production electric/hydraulic winches, windlasses and commercial equipment is available. Muir cater for custom designed equipment to suit your requirements.

Muir is accredited by DNV, to ISO 9001 Quality Assurance System. Equipment is tested to most classification societies.

TECHNICAL INFORMATION

The company has adopted the corporate policy of manufacturing and selling products which have the recognised standard of quality that satisfies customers throughout the effective life span of the product.

It is therefore an essential requirement of this stipulated policy for Muir to produce and supply its customers with products which are suitable for their intended purpose, and which are in conformity with the relevant and agreed specification or contract

The procedures outlined in our quality assurance manual describe how the quality system is designed to ensure that customer requirements are recognised and that consistent control of these requirements is established, implemented and maintained.

Strict adherence to the policy stated above is a requirement of every aspect of Muir.

In compliance with our quality policy, the following pages containing specification and drawings are all available in paper copy. AutoCAD drawings are available in disk form or via the internet in a range of file types.

Standard builds for commercial equipment are steel or cast steel grit blasted clean, zinc primed and coated with white epoxy enamel unless otherwise specified.

Winch components may also be supplied in polished bronze, chrome bronze, stainless steel, alloy, cast steel or cast iron as specified by Muir or customer in writing or at time of purchasing to suit the designers and owners requirements.

Motor drives and gearboxes are finished in white gloss with non-corrosive weight saving marine alloy components use where practicable.

Heavy-duty brake design on some models may not require use of chain stoppers or chain compressors depending on classification society rules.

Devils Claws, Chain Rollers, Chain Stoppers and Chain Compressors are available for all sizes of anchor chain.

Drum winch weights are nett for steel build direct drive models. Dog clutch models refer Muir factory for weight details.

On placing an order we prefer a chain sample, including joining links and kenter shackles (if they are to be accommodated). Due to widening of gypsy pattern casting.

We supply a range of AC/DC electrical or hydraulic controls and accessories for the following winches and equipment.

DEFINITIONS: FOR APPLICATIONS IN THIS CATALOGUE

Windlass – A vertical or horizontal mechanical apparatus (hand, electric or hydraulic) for pulling or hoisting anchor and cable (chain or synthetic rope), incorporating a circular chain wheel or gypsy with four or five pockets into which anchor chain links fit snugly. Synthetic three strand nylon lines can be pulled in the chain wheel if the design incorporates a grooved vee section with an appropriate stripper and tensioner to drive the rope.

WINCH – A vertical or horizontal apparatus used for hoisting or pulling purposes incorporating a storage drum around which is wrapped wire cable or rope, mechanically activated by hand, electrical or hydraulic power.

Certified and Accredited Quality

GLOSSARY OF TERMS

Rating – Is the maximum pull, load, that can be applied to the winch/windlass for short periods.

Working Load – As stated or recommended by the relevant classification society. Otherwise this is the maximum continuous load of the windlass.

Gypsy – Chain wheel, Wild Cat.

Model Numbers – Product numbers are not indicative of the lift capacity, rating or working load.

OPTIONS: CONTROLS, STARTERS AND ACCESSORIES

The design of the preferred starting system must be considered.

Control cabinets and starters for single speed, dual speed and variable speed AC motor can be supplied to customer requirements.

It should be noted the vessel's generating capacity needs to be capable of starting the deck machinery on high load.

Foot operated, remote and hand held controls are available for hydraulic and electric windlasses and capstans.

For more detail refer to Master Control and Accessories Section on page 36. Hydraulic and electrical circuitry if required, will be at customers cost.

MOTOR PROTECTION

All electric motors must be protected from overload by appropriate circuit breakers (or fuses). Thermistors are available for protection of overheating of AC motors and should be connected to circuit trip relays to also provide overload protection. Heaters can also be fitted to avoid condensation.

Hydraulic motors must be protected by relief valves. Counter balance valves must be fitted to hydraulic gear drives to prevent run back.

CHAIN GYPSIES

Are available to suit ISO, DIN 766, Studlink and Shortlink calibrated chains.

CUSTOM DESIGNED WINDLASSES

Custom designed windlasses for specialised installations can be supplied on request.

CLASSIFICATION PERFORMANCE AND TYPE APPROVAL

Classification requires a minimum lifting speed of 9 metres/minute and Muir designs have optional two speed systems in hydraulic or AC drives up to 18M/M.

Muir is able to build to specific classification society requirements including ABS, Lloyds, DNV, NKK, GL, RRR, RMSR, BV, KR, CCS, and compliance with MCA and USL codes.

Muir products are sold and serviced through distributors, agents and yards worldwide.



RATING CAPACITY

Rating capacity is based on maximum shortlink chain size and standard

Electric and hydraulic motors. Other chain sizes and optional motors will effect the capacity and speed.

ABBREVIATIONS

DC	Direct Current
AC	Alternating Current
HYD	Hydraulic
gal	Gallons (US)
lt	Litres
MPa	Megapascal
PSI	Pounds per square inch
lb	Pound
kg	Kilogram
Min	Minute
M	Metre
mm	Millimetre
"	Inch
' / ft	Feet

© All products in this catalogue and on disk are copyright to Muir Engineering 2013. All rights reserved. No images or information may be reproduced without the prior permission of the copyright owner. Product designs for use by Muir Engineering only. Products herein are NOT to be manufactured or produced by any other persons.

While all due care and attention has been taken in the preparation of this catalogue no responsibility shall be taken for errors or omissions. THIS DOCUMENT SHOULD NOT BE USED FOR INSTALLATION PURPOSES

Any reference to MUIR or MUIR'S in this catalogue implies MUIR ENGINEERING GROUP PTY. LTD. MUIR reserves the right to change specifications without notice.



Anchoring and Fishing Drum Winches

General Description

The lightweight and versatile SD Series have been developed for multiple purpose work boats uses including fast ferries, charter, defence, offshore and on shore applications. Winches can be supplied as a complete package including electrical cabinets controls and power units. Class Certification is available for all models. Capstans are optional.

FOR ANCHORING, MOORING, FISHING AND LIFTING PURPOSES.

Drum Winches are popular today in anchor winching operations having the benefit of storing the steel cable or nylon line on the drum and the anchor chain over the top. This style of installation does not require a chain locker below the deck which is often not designed into high speed or shallow draft vessels. Drive power is available in Hydraulic or Electric AC 200-400 Volts, 3PH, 50 or 60HZ and also 24V on some smaller models.

Decutching the anchor and chain to freefall can be achieved by way of a mechanical sliding Dog Clutch with external braking on the winch drum. Hydraulic Direct Drive and Piston Motor designs are able to achieve freefall hydraulically using special valving components.

The SD250 & SD350 PP (Power Pack) Lightweight model Drum Winch are available incorporating the AC / Hydraulic power pack on the base plate and for ease of installation and only requires electric power to the motor and is ready to operate.

Single and Twin Drum Fishing Winches and Net Reels for Tuna, Trawling and Oceanographic purposes are available in various sizes.

A range of general purpose Drum Winches from 100kg to 10,000kg can be supplied for many general winching purposes.

In the designing installation and servicing of winching products, the safety, reliability and long term quality are of the utmost importance.

DOG CLUTCH DRIVES

Electric: Winches and Windlasses built to classification Society rules with

heavy duty dog clutches between the drive, drum or chain gypsy ensures there is no slippage in case of stall or seizure of the anchor, or when the anchor comes home. It is necessary to install a torque limiter on AC models to allow slippage between the AC motor and geardrive protecting the equipment.

HYDRAULIC DRIVES

Anchoring equipment manufactured to classification society rules and with Hydraulic drive systems are fitted with pressure relief valves, and in the event of excessive load or anchor stall bypasses the pressure back to the Hydraulic reservoir. Counter balance valves are required to prevent run back, at additional cost to the winch/windlass.

CONE CLUTCH DRIVES

Cone Clutch Drives by design allow slippage at excessive loads and do not require torque limiter installation. The load at which slippage takes place can be determined by the amount of pressure applied to the clutch. This option is available on the SD100 model.

CONTACT US

If you have a winching need for either onboard or onshore please contact Muir for your nearest distributor. Two additional catalogues are also available for Pleasure craft and Mega Yacht equipment.

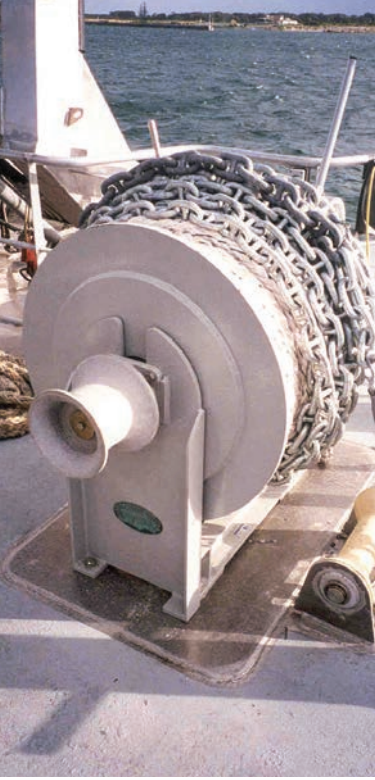

Custom Designed 3 Tonne Winches SD3

General Assembly
(AC/HYD Motor)

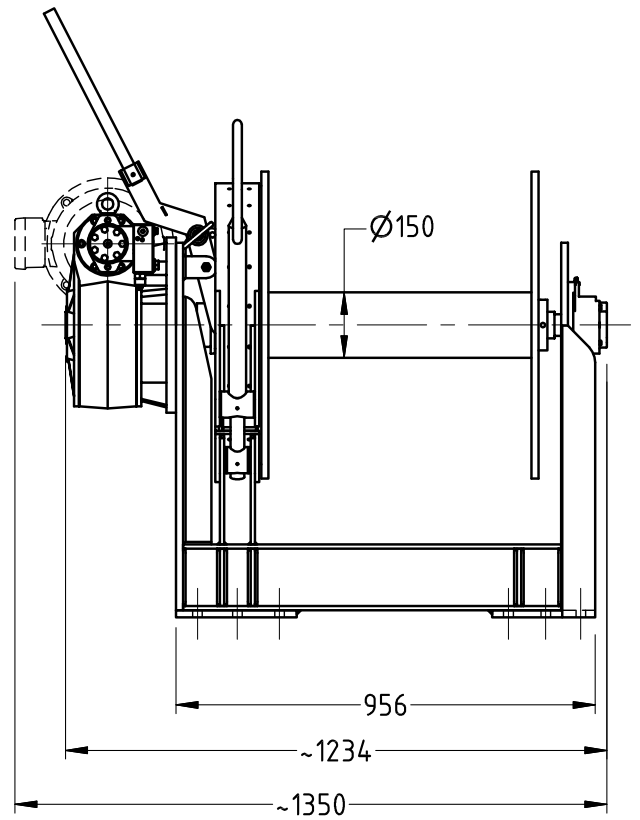
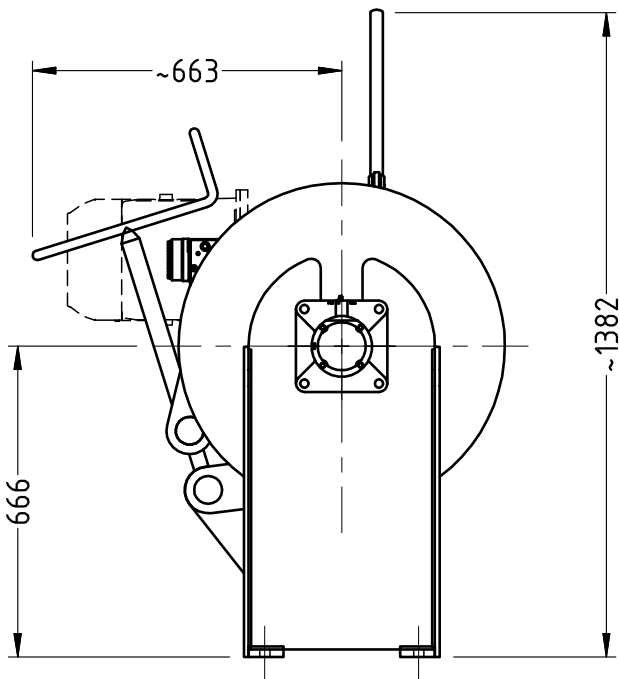
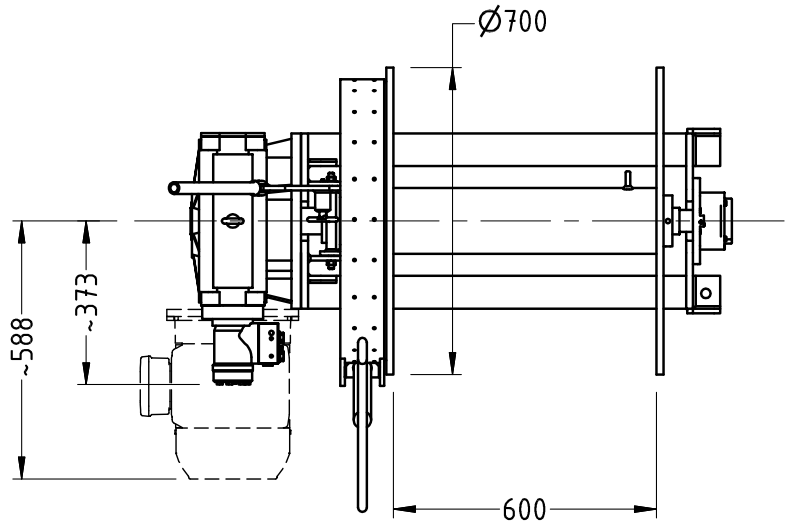

SD Series

Powerhouse for anchoring and mooring on fast ferries, yachts, and smaller vessels. (electric, hydraulic)

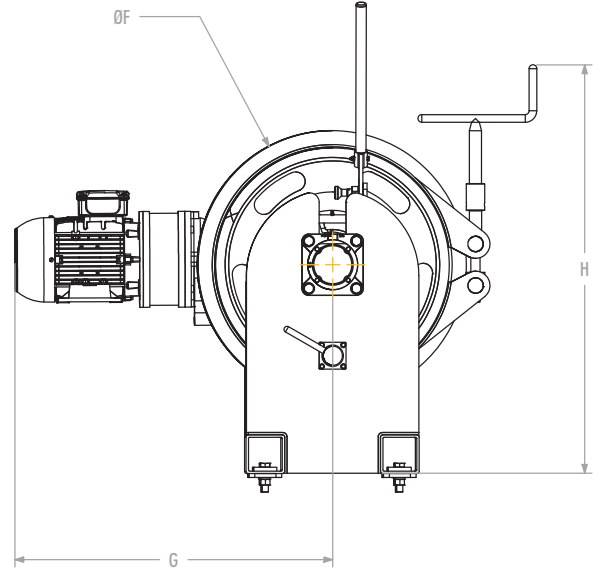
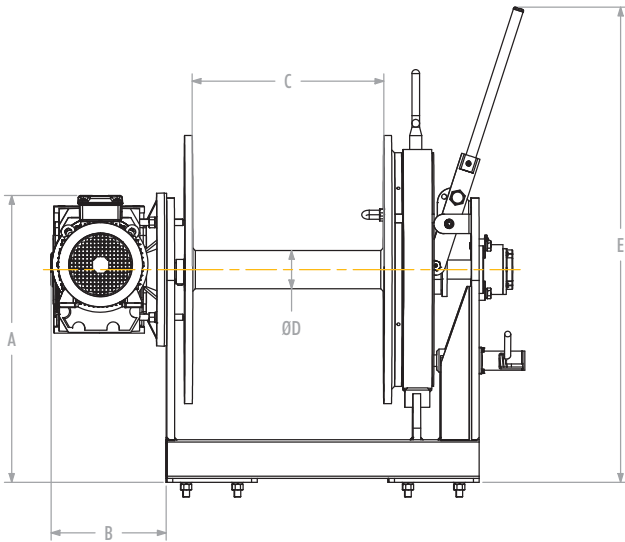
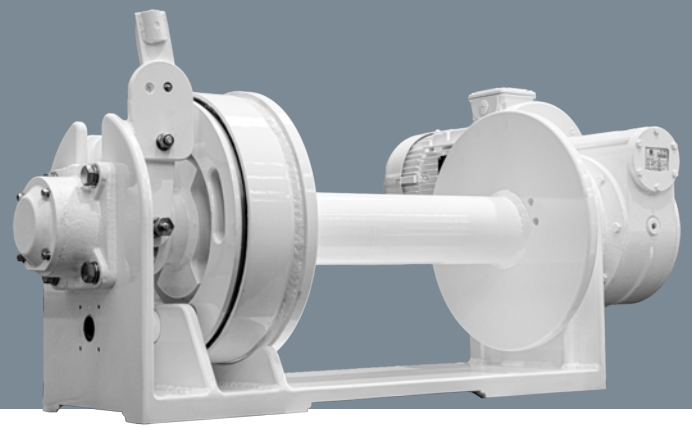

MEASUREMENTS

DIMENTION	SD100	SD150	SD250	SD350	SD450
A	516.9 cm [203.50 in]	730 cm [287.40 in]	738.4 cm [290.71 in]	890.4 cm [350.55 in]	834 cm [328.35 in]
B	262.5 cm [103.35 in]	276.5 cm [108.86 in]	300.2 cm [118.19 in]	304.5 cm [119.88 in]	459 cm [180.71 in]
C	490 cm [192.91 in]	480 cm [188.98 in]	500 cm [196.85 in]	500 cm [196.85 in]	450 cm [177.17 in]
D	106 cm [41.73 in]	106 cm [41.73 in]	100 cm [39.37 in]	150 cm [59.06 in]	450 cm [177.17 in]
E	886.6 cm [349.06 in]	1000.2 cm [393.78 in]	1230.2 cm [484.33 in]	1189.2 cm [468.19 in]	
F	387.5 cm [152.56 in]	500 cm [196.85 in]	700 cm [275.59 in]	700 cm [275.59 in]	1080 cm [425.20 in]
G	469 cm [184.65 in]	633.6 cm [249.45 in]	820.2 cm [322.91 in]	740.3 cm [291.46 in]	
H	658.9 cm [259.41 in]	872.9 cm [343.66 in]	1065.7 cm [419.57 in]	967.3 cm [380.83 in]	

DRIVES

MODEL	ELECTRIC DRIVE		HYDRAULIC DRIVE	
	Input Power (KW)	Power Supply	Hydraulic Flow (l/min)	Pressure (bar)
SD100	3 / 4 KW	24V, 208/415V, 50/60Hz, 3PH	24 litres/min	140 Bar
SD150	3 / 4 KW	208/415V 50/60Hz 3PH	27 litres/min	100 Bar
SD250	4 / 5.5 KW	208/415V 50/60Hz 3PH	27 litres/min	110 Bar
SD350	7.5 KW	208/415V 50/60Hz 3PH	35 litres/min	125 Bar
SD450	N/A	N/A	46 litres/min (30 min rating)	85 Bar (30 min rating)

OTHER SPECIFICATIONS

MODEL	Lifting Force	Recovery Speed	Brake Holding Power	Drum Capacity	Construction	Weight
SD100	6 - 7kN (AC)	9M/min (minimum)	110kN	120M of 12-14mm cable or 10M of 16mm chain	Steel/Alloy	AC Steel 320kg/Alloy 100kg
	7 - 8kN (HYD)					HYD Steel 320kg/Alloy 100kg
SD150	10 - 11kN (AC)	9M/min (minimum)	110kN	150M of 12-14mm cable or 10M of 16mm chain	Steel/Alloy	AC Steel 320kg/Alloy 230kg
	15 - 16kN (HYD)					HYD Steel 270kg/Alloy 190kg
SD250	11 - 13kN (AC)	9M/min (minimum)	140kN	160M of 16-18mm cable or 10M of 17.5mm chain	Steel/Alloy	AC Steel 450kg/Alloy 420kg
	17 - 18kN (HYD)					HYD Steel 450kg/Alloy 380kg
SD350	15 - 16kN (AC)	9M/min (minimum)	190kN	180M of 20.5mm cable or 10M of 20.5mm chain	Steel/Alloy	AC Steel 610kg/Alloy 520kg
	15 - 16kN (HYD)					HYD Steel 610kg/Alloy 520kg
SD450	27 - 30kN (HYD)	9M/min (minimum)	420kN	200M of 30mm cable or 15M of 28mm chain	Steel	HYD Steel 1120kg

**Docking Capstan
Optional**

**Class Certification
Optional**

**Finish
Steel**
Grit blast epoxy

Alloy/Aluminium
Enamel over zinc primer

SGC Series

Powerhouse for anchoring and mooring on fast ferries, yachts, and smaller vessels. (electric, hydraulic)

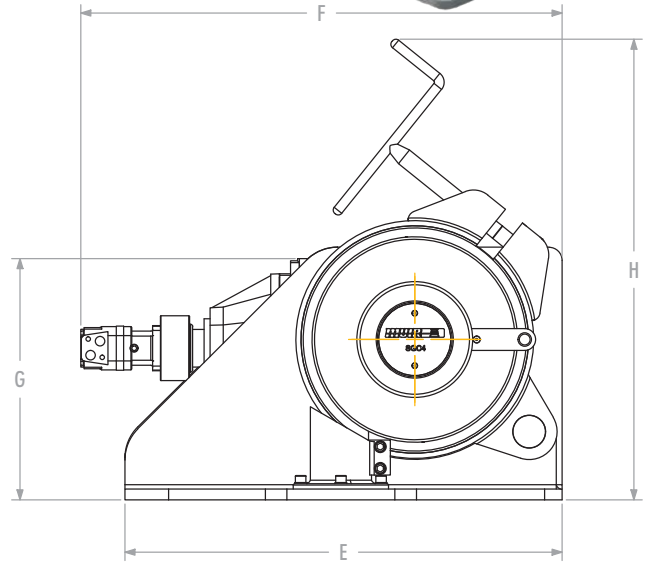
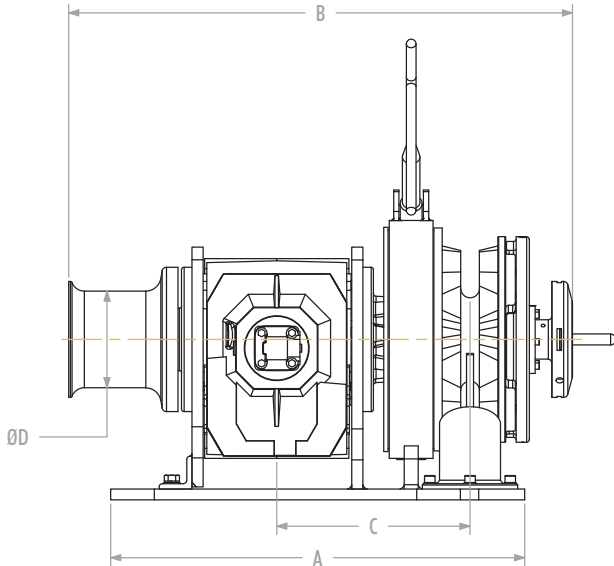

MEASUREMENTS

DIMENTION	SGC1	SGC2	SGC3	SGC4
A	374 cm [147.24 in]	379 cm [149.21 in]	380 cm [149.61 in]	947 cm [372.83 in]
B	715 cm [281.50 in]	732 cm [288.19 in]	754 cm [296.85 in]	1153 cm [453.94 in]
C	313 cm [123.23 in]	283 cm [111.42 in]	280 cm [110.24 in]	442 cm [174.02 in]
D	138.9 cm [54.69 in]	181 cm [71.26 in]	181 cm [71.26 in]	221 cm [87.01 in]
E	390 cm [153.54 in]	500 cm [196.85 in]	500 cm [196.85 in]	1000 cm [393.70 in]
F	714.6 cm [281.34 in]	616 cm [242.52 in]	1000 cm [393.70 in]	1101 cm [433.46 in]
G	402.5 cm [158.46 in]	458 cm [180.31 in]	525 cm [206.69 in]	552 cm [217.32 in]
H	706.8 cm [278.27 in]	748 cm [294.49 in]	825 cm [324.80 in]	1054 cm [414.96 in]

DRIVES

MODEL	ELECTRIC DRIVE		HYDRAULIC DRIVE	
	Input Power (KW)	Power Supply	Hydraulic Flow (l/min)	Pressure (bar)
SGC1	3/4 KW	24V DC/ 3PH	30 litres/min	100 Bar
SGC2	4 KW/5.5KW	50HZ & 60HZ / 3PH	38 litres/min	100 Bar
SGC3	5.5 KW/7.5KW	50HZ & 60HZ / 3PH	38 litres/min	100 Bar
SGC4	7.5 / 9.2KW	50HZ & 60HZ / 3PH	40 litres/min	100 Bar

OTHER SPECIFICATIONS

MODEL	Rating	Recovery Speed	Band Brake	Chain Size		Construction	Weight	Class Certification Optional
				SHORT	STUD			
SGC1	DC ~12kN 1200kg	10M/min (minimum)	316	16mm	16mm U2	Steel	AC 180kg	Finish Steel Zinc primed, or coated with epoxy enamel
	HYD ~17kN 1700kg						HYD 150kg	
SGC2	AC ~14kN 1400kg 2600kg - Brake Holding	10M/min (minimum)	Mild steel or 316	Up to 19mm	Up to 19mm U2	Steel	AC 250kg	
	HYD ~22kN 2200kg 2600kg - Brake Holding						HYD 150kg	
SGC3	AC ~23kN 2300kg 8200kg - Brake Holding	10M/min (minimum)	Mild steel or 316	Up to 22mm	Up to 20.5mm U2	Steel	AC 130kg	
	HYD ~27kN 2800kg 8200kg - Brake Holding						HYD 370kg	
SGC4	AC ~24kN 2500kg 25000kg - Brake Holding	10M/min (minimum)	316	22mm	Up to 24mm	Steel	AC 1400kg	
	HYD ~42kN 4300kg 25000kg - Brake Holding						HYD 1200kg	

RW Series

Powerhouse for anchoring and mooring on fast ferries, yachts, and smaller vessels. (electric, hydraulic)

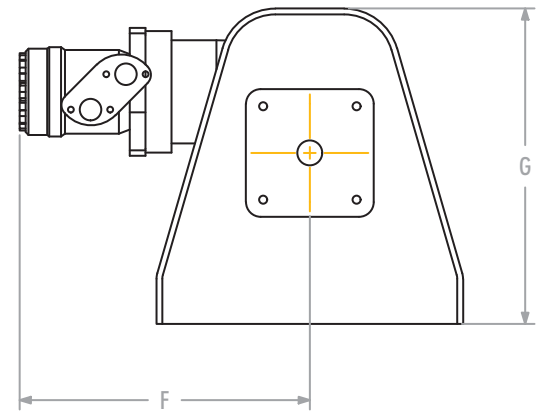
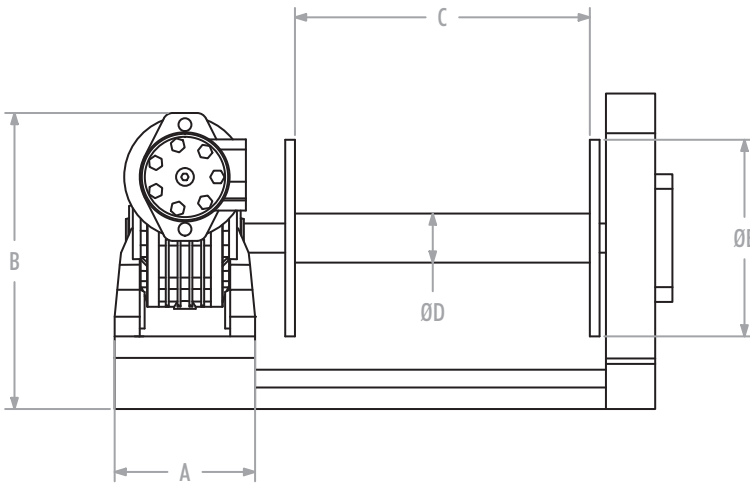
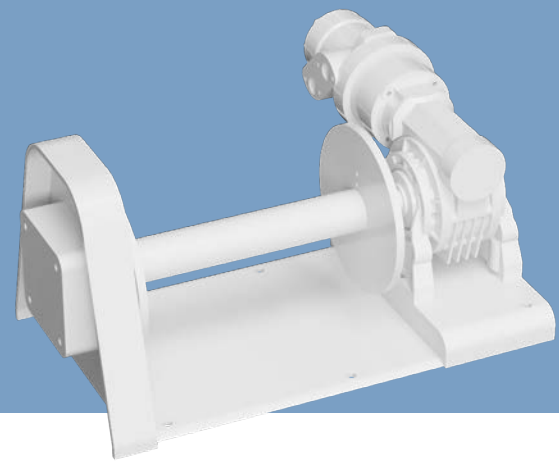

MEASUREMENTS

DIMENTION	RW3300	RW6600
A	143 cm [5.63 in]	186 cm [7.32 in]
B	301 cm [11.85 in]	349 cm [13.74 in]
C	300 cm [11.81 in]	300 cm [11.81 in]
D	50 cm [19.69 in]	73 cm [28.74 in]
E	200 cm [78.74 in]	200 cm [78.74 in]
F	295 cm [116.14 in]	433 cm [170.47 in]
G	321 cm [126.38 in]	349 cm [137.4 in]

General Purpose Winches are designed for a multiple of uses such as raising and lowering boats up to 3000 kg on ramps, slipways and beach trailers and general marine lifting and pulling purposes. Constructed from steel with a gloss enamel finish, fitted with a worm drive gearbox and water-resistant electric motor. The winches are fully reversible. Options include weatherproof electrical starting cabinet, up down switch plus a hand pendant and lead if required. AC/DC power or hydraulic.

PERFORMANCE CRITERIA

MODEL	RW3300/63	RW6600/86
Power Supply	12/24/HYD/AC 50HZ	12/24/HYD/AC 50HZ
Rated Lift	400kg (~4kN)	820kg (~8kN)
Motor Size	1.0 -1.5KW	2.0KW
Speed	3M/min	3M/min
Capacity	60M x 6mm	80M x 6mm
Construction	Steel or Stainless Steel	Steel
Finish	Gloss enamel	Gloss enamel
Hand Pendant	Optional	Optional
240/415 Switch Control	Optional	Optional
Weight (approx.)	65kg	85kg



DOCKING Capstans

**General Arrangement
(HYD/ELEC/PLANETARY Drive)**

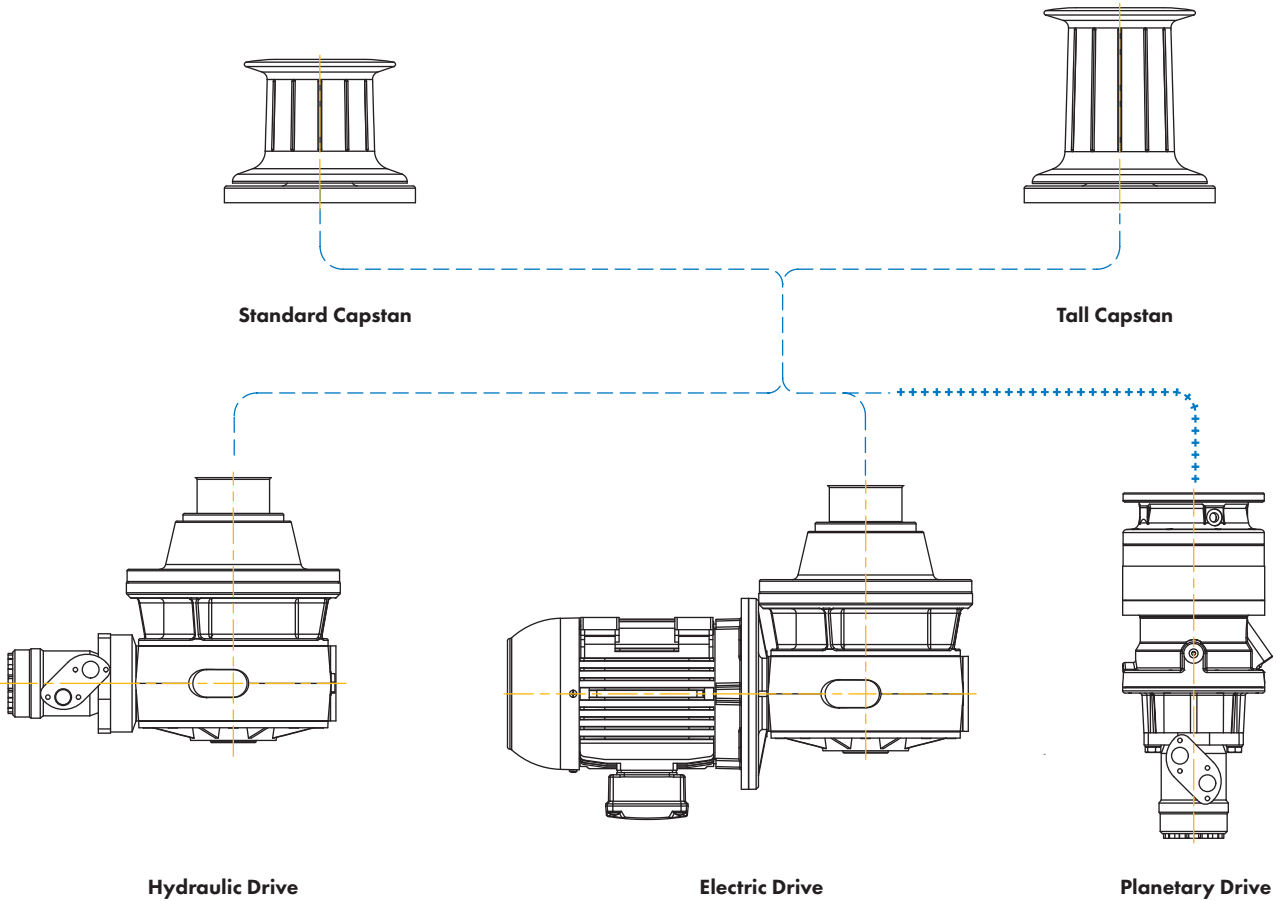

Capstans are usually located on the aft deck to assist in the mooring of the vessel. Foot switch and remote controls can operate capstans. Capstans are supplied with 90° or inline drives for compact installation.

Capstans can be serviced with deck plate intact from top and bottom side.

Capstan selection should be considered with warping line sizes and flexibility of warp.

For more detailed information for your specific requirements visit muir.com.au



Vertical Mooring Anchor Winches

General Arrangement (HYD/ELEC/INLINE Drive)

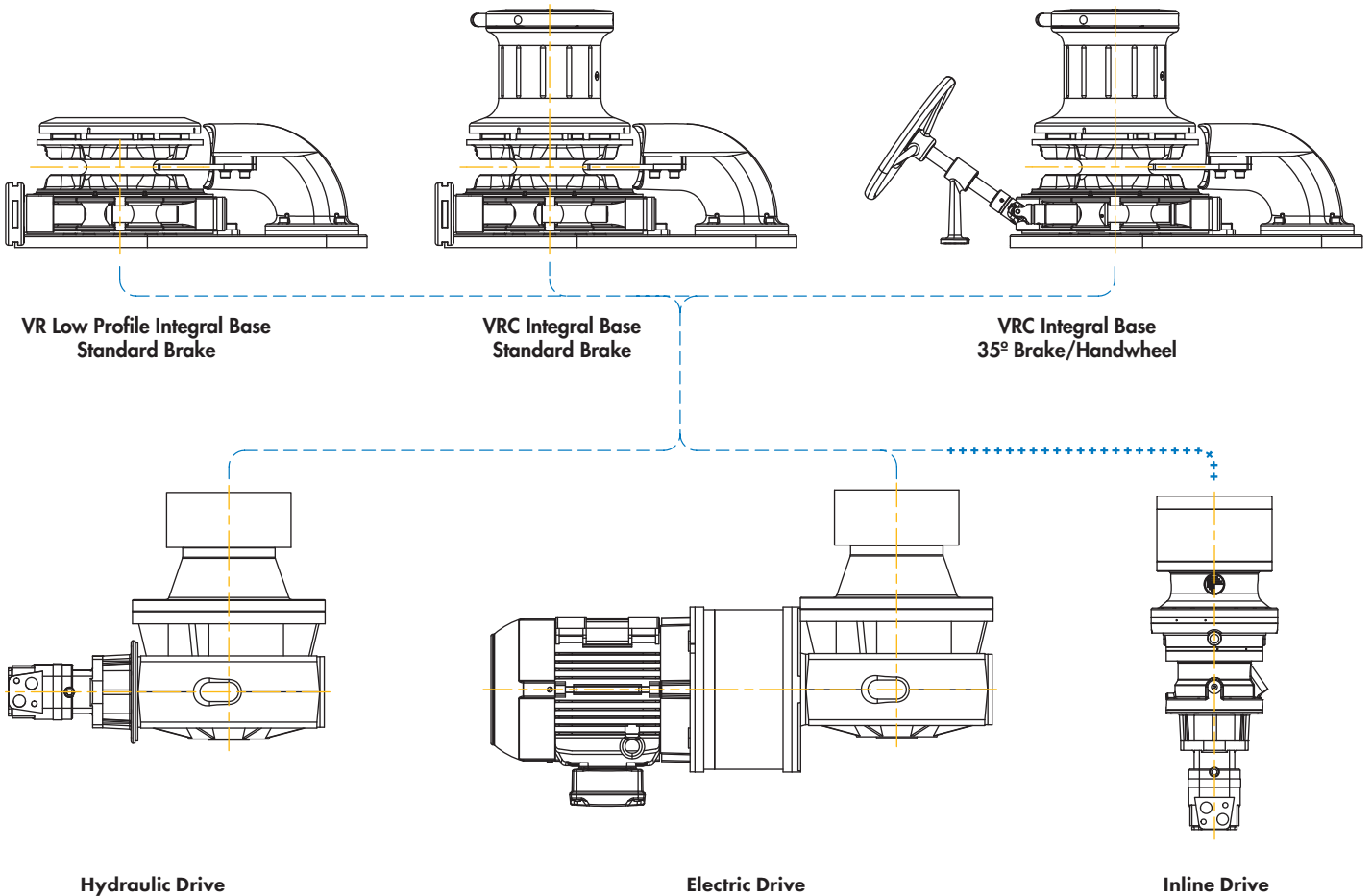

These windlasses have a main vertical shaft and horizontal gypsy.

The vertical configuration allows for single and twin installations with the advantage of installing the windlasses in various positions.

This facilitates the positioning of hawser pipes, chain pipes and anchors. In some cases it may be preferable to install windlasses closer to the centre line or further apart.

Muir vertical windlass design innovation enables the running gear to be stripped from above the deck plate and to remove the drive gear from below deck with the deck plate and chain pipe or chain pipe roller intact.

Under deck rigid self aligning gear drive-to deck plate couplings ensures alignment is maintained at all times with the advantage of locating the gear drive in multiple and preferred positions below deck.

Verticals require less deck space and vertical winches have operational advantages for mooring purposes due to the radial scope of the lead.

For more detailed information for your specific requirements visit muir.com.au

Horizontal Anchor Winches for Pleasure & Commercial Vessels

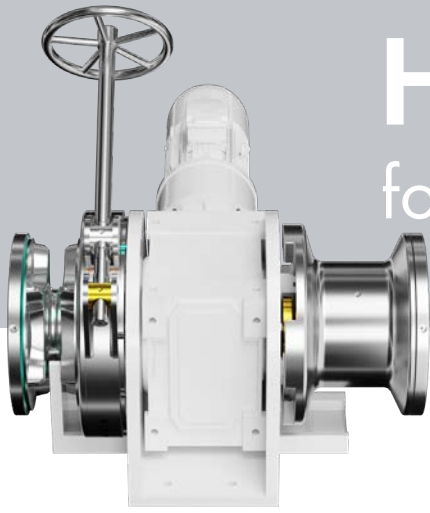

STANDARD FEATURES

- Single capstan to port, gypsy to starboard
- Reversible motor
- Independent operation of gypsy and capstan
- Heavy duty totally sealed gearbox with ground worm drive and tapered roller bearings in oil bath

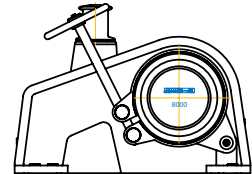
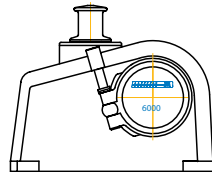
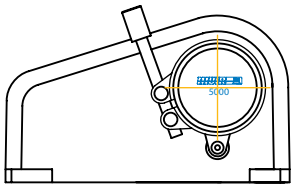
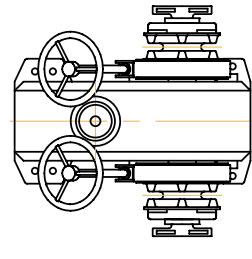
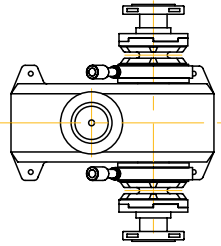
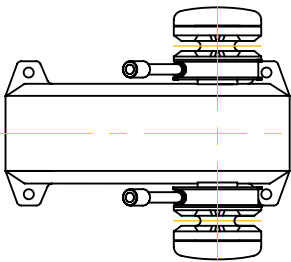

HR5000

HR6000

HR8000

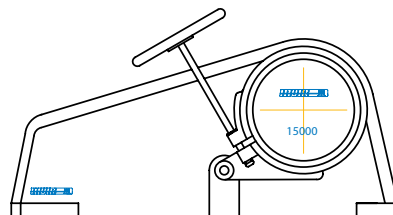
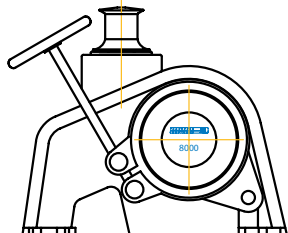
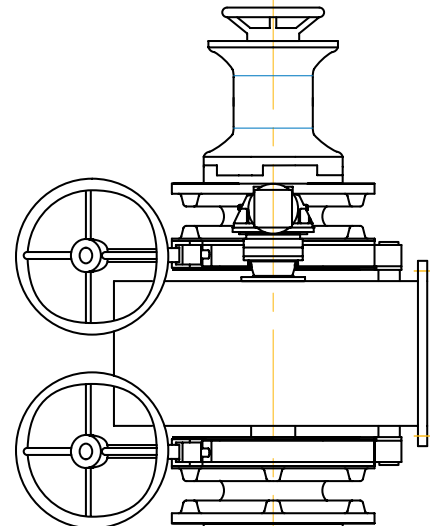
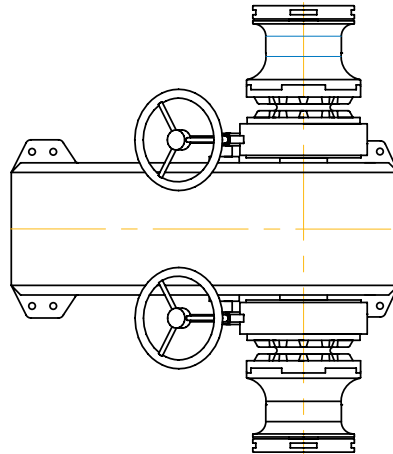
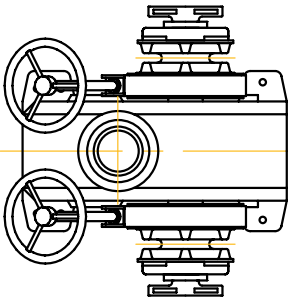

HR11000

HR15000

HR22000



Gunwhale Hauler Capstan

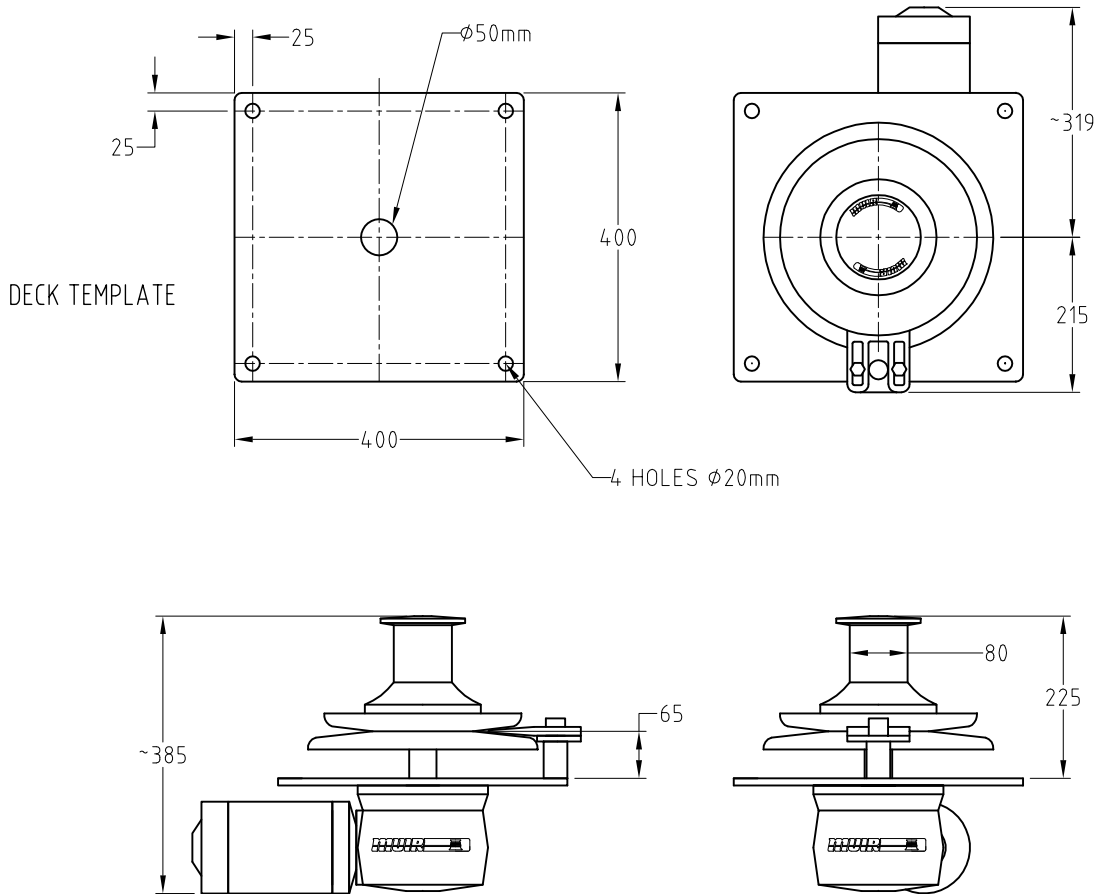

DIMENSIONS OF OVERSIDE HAULERS

A range of • Alloy • Bronze • Stainless Steel Line Haulers and Heads

12" (300) 14" (350) 16" (400) 18" (450) 20" (500) 24" (600)

Diameter taken from the base of disk.

PERFORMANCE CRITERIA

MODEL	GUNWHALE HAULER CAPSTAN	
Power Supply	A/C D/C	HYDRAULIC
Input Power	2 KW	HYD
Hydraulic Flow	-	40 litres/min
Hydraulic Pressure	-	60 Bar
Lifting Force	150kg	200kg
Recovery Speed	60M/min	60M/min
Warping Capstan	Optional	Optional
Construction	Alloy	Alloy
Finish	White Enamel motor / gear	White Enamel motor / gear
Weight	-	-

LINE HAULING EQUIPMENT

A large combination of fishing gear is manufactured to operate in either the vertical or horizontal position with Alloy or Bronze vee heads used for Droplining, Crab and Cray fishing and Long Lining for light and heavy hauling.

The Gunwhale Hauler Capstan is a light duty line hauler for hauling and recovery of rope such as long lining, lobster traps, crayfish pots, and recovery of buoy weights and dan poles. Available with 12 & 24 Volt DC and Hydraulic Drives. The unique space saving design allows convenient gunwhale mounting saving deck space especially for smaller craft. Fitted with a 330mm-diameter alloy head, alloy capstan & rope tailing peeler provides an easy and safe operation.

Alloy or stainless steel mounting.



Chain Stoppers/Compressors/Devil's Claws

CHAIN STOPPERS

CHAIN SIZE SHORT LINK	A	B	C	D	E
10mm	112	150	88	28	44
13mm	130	185	111	33, 32	54
16mm	197	235	138	43	69.5
	198	238	143	41	70
	192	235	136	42	70
198	238	136	42	70	
CHAIN SIZE STUD LINK	A	B	C	D	E
16mm	209	235	138	43	82
	193	236	143	42	82
	209	238	143	42	82
17.5mm, 19mm	230	285	207	50	94
	230	285	202	50	94
20.5mm, 22mm, 24mm	270	300	205	65	116
20.5mm, 22mm	270	300	205	54	116
24mm, 26mm	280	280	255	71	110
28mm	310	375	256	55	134
34mm	350	385	275	50	160
38mm	388	460	350	76	180

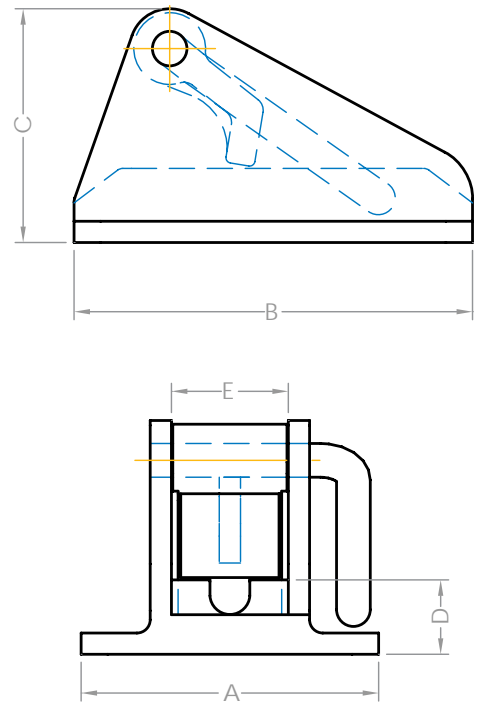

Chain stoppers are strongly recommended for safe anchoring to protect and remove load from the windlass when at anchor, and to prevent accidental free fall of the anchor while under way. The hinged pawl allows the chain to be pulled up automatically, and is easily disengaged to deploy the anchor. To suit all chain types up to 38mm (1 1/2") with optional finishes in chromed bronze, traditional polished bronze, highly polished or bead blasted 316 stainless steel.

CHAIN STOPPER DEVIL CLAW

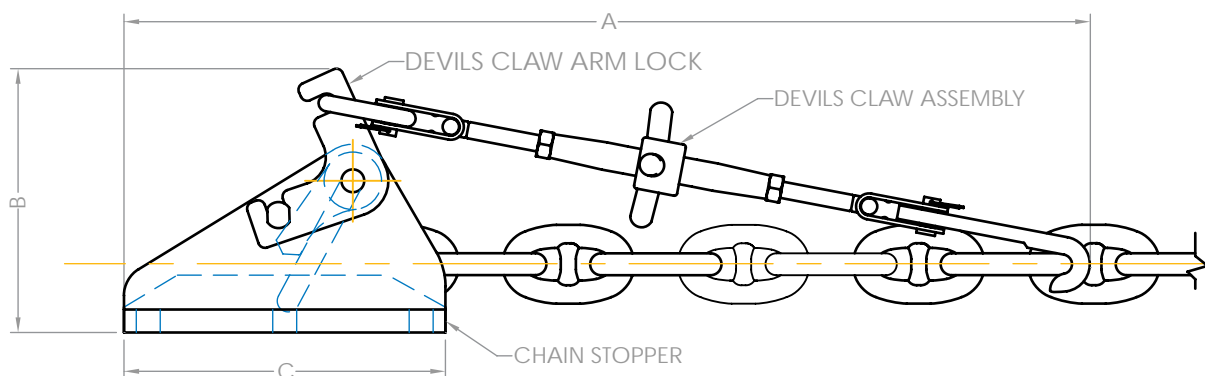

CHAIN	A	B
10mm	472	126
13mm	524	1632
14mm, 16mm	688	199
17.5mm-19mm	841	248
21.5mm, 24mm	857	280

Following the same principal of the conventional chain stoppers we combine a separate devil claw, this unique arrangement offers additional safety. The devil claw hooks onto the chain and provides tension on the chain while the anchor is stowed ensuring additional hold while underway. The devil claw can be easily removed or simply secured off to the side. The combined set provided increased safety. Available to suit chain up to 38mm (1 1/2"), and finished in highly polished or bead blasted 316L stainless steel.

Chain Stoppers/Compressors/Devil's Claws

CHAIN COMPRESSOR

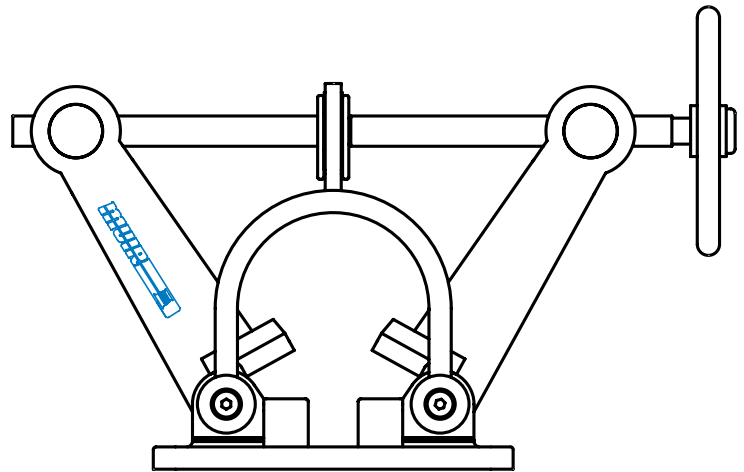
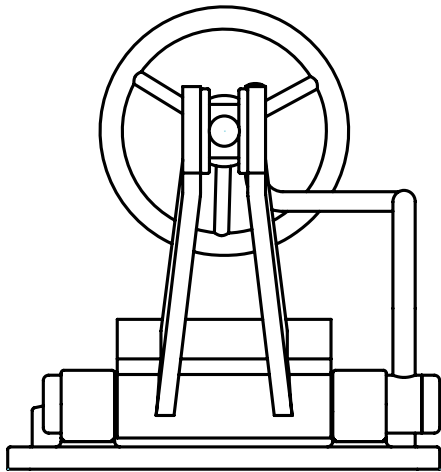

CHAIN SIZE (mm)	A	B	C	D	E	F	G	H	I	
10	69	116	69	CHAIN STOPPERS						
13	85	118	85							
16	138	197	138							
19	205	230	205							
21	215	260	215							
24-30	265	320	265							
34	275	350	275							
38	350	388	350							
12.5-17.5	COMPRESSORS			255	175	281	220	210	275	
17.5-26				324	262	281	322	300	368	
26-36				425	370	281	420	360	430	

Chain Stoppers, Compressors and Devil's Claws are strongly recommended for safe anchoring by taking the load off the windlass and preventing damage to vital components, especially in severe conditions. Chain compressor clamps the chain via a lever system operated by a handwheel and stainless steel spindle. Chain lock relies on a tongue locking into the chain links preventing the chain from running out. Devil's claws tensions up chain and anchor to ensure safety while travelling.





Alloy Hatches

550 Clear Opening Square Hatch

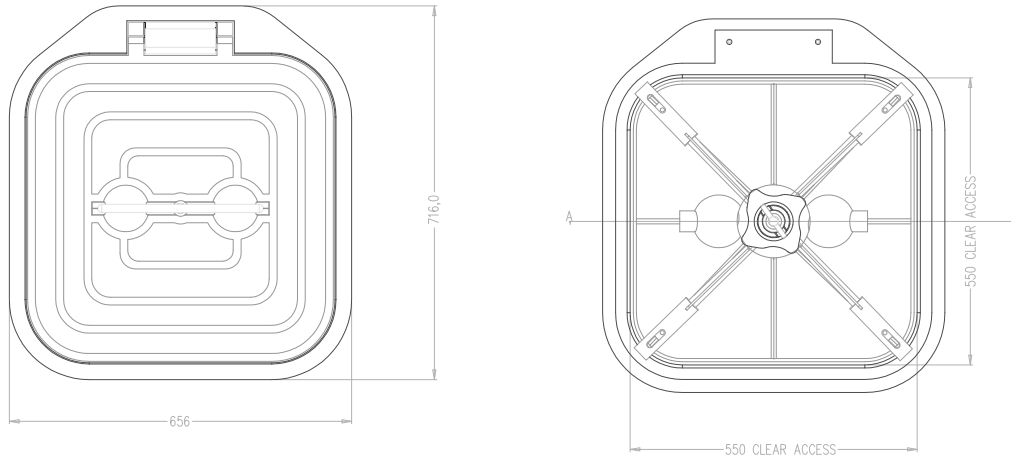

Hinged Oval Deck Hatch General Arrangement

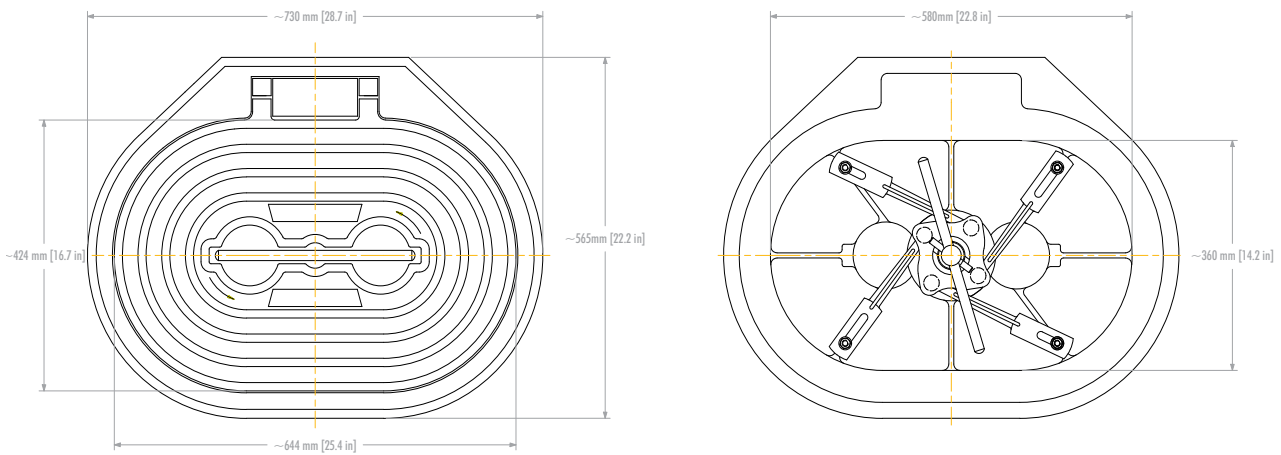

PERFORMANCE CRITERIA

Round Hatches		Oval Hatches	
591601	Standard, 620mm dia	591501	Standard 580x360mm
591600	With internal handle	591500	With internal handle
591650	Deck ring alloy	591550	Deck ring alloy
591651	Deck ring steel	591551	Deck ring steel

Muir Alloy Oval and Round Hatches with water tight seal and optional quick release handles flush deck access or escape hatch, engine room and stowage compartment hatches.

Constructed from marine grade alloy, water tight seal inside and outside operation.

Built to DNV Standard. Hinged and non-hinged versions available.

Alloy Hatches

Oval Deck Hatch General Arrangement

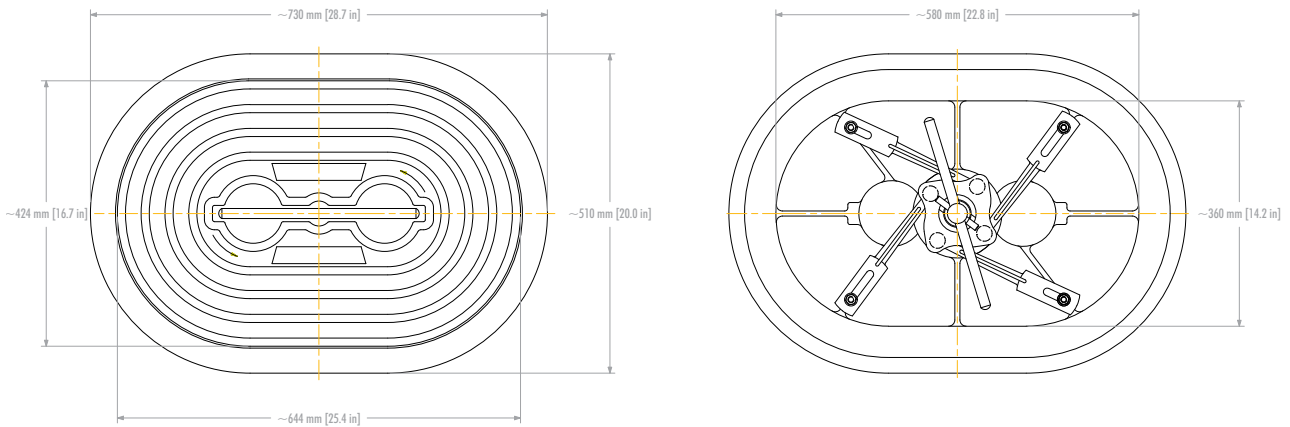

Round Deck Hatch General Arrangement

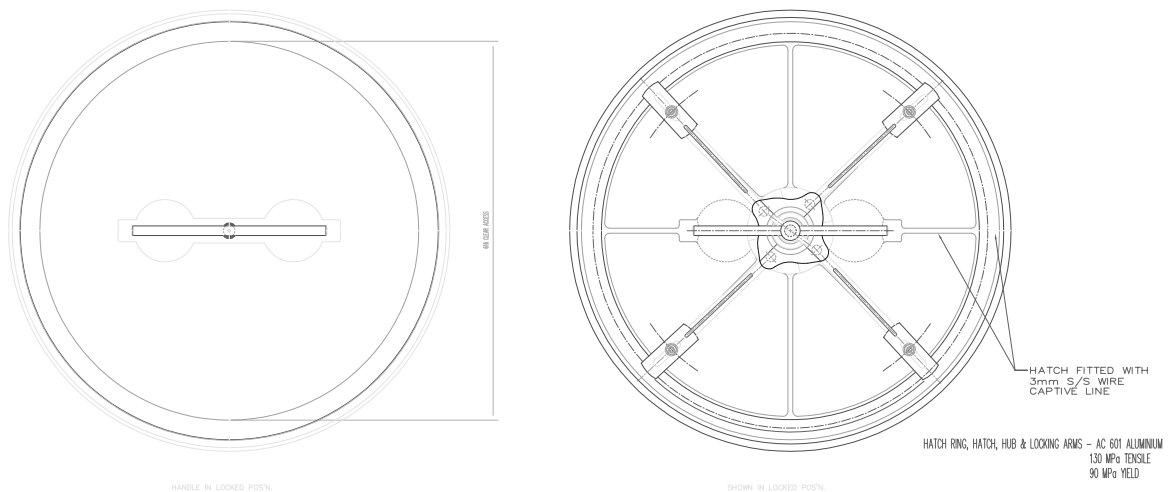

ANCHORING SYSTEMS ACCESSORIES



CHAIN PIPE (CP)

Facilitate the feeding of the anchor rode through into the locker. Available in 316L stainless steel, chrome bronze or polished bronze finish, to suit all models and chain up to 30mm U2 (1 3/16").



ANCHORS

Various configurations and sizes for all vessels available including the popular HHP and SHHP in galvanized and stainless steel finishes.



CONTROL CABINETS

Configured to suit all windlass voltages and applications in single, two or variable speed and for control of single or multiple windlasses and capstans. Finished in stainless steel or various coloured coatings, these units can be supplied to comply with classification requirements.



MUIR CHAIN + ANCHORS

A wide range and grades of galvanized, black, high tensile, studlink and shortlink chain available. Tested to comply with mechanical properties and ISO standards. Studlink chain can be supplied with test certificates to comply with all classification society requirements.

ANCHORING CONTROLS



CHAIN COUNTER ENABLED

Auto Anchor AA150 Kit



AA150 CONTROL AND COUNTER

(Chain Counter Readout Only)

Standard Package

- Sensor with 2m cable
- 2 X Magnet
- Load sensing connectors
- Installation/Operation booklet

Not included

- Plug-and-play sensor extension
- Sensor Holder (For horizontal windlasses)

Additional connectors, consoles, base stations and antennas sold separately.

* Please refer to the installation manual for your specific installation requirements.

FEATURES

- Rode length monitoring from the helm.
- Large LCD display with adjustable red backlighting shows length of anchor rode deployed. Display in feet or meters.
- Docking alarm warns skipper when anchor is close to docking.
- Pre-programmed calibrations for rope/chain rodes.
- Install up to two units or combine with the AA550RC, AA500C or AA601 for multiple stations.
- Standard 60mm (2.36") marine instrument console.

Auto Anchor AA560 Kit



AA560 CONTROL AND COUNTER

(Up/Down Control + Chain Counter Readout)

Standard Package

- Sensor with 2m cable
- 2 X Magnet
- Load sensing connectors
- Installation/Operation booklet

Not included

- Plug-and-play sensor extension
- Sensor Holder (For horizontal windlasses)

Additional connectors, consoles, base stations and antennas sold separately.

* Please refer to the installation manual for your specific installation requirements.

FEATURES

- Improved contrast on the LCD
- Automatic Sensor Detection – no need to select sensor in the set up
- Manual control stop at docking distance – stops the windlass during retrieval when using manual and automatic operation
- Swap controls option in the set up – this option means the Up button can be used as Out and the Down button can be used as In
- Drum windlass counting capability
- Improved troubleshooting – Simplified diagnostics and built in voltmeter with expanded technician diagnostics

Auto Anchor AA710 Kit



WIRELESS

(Up/Down Control + Chain Counter Readout)

Auto Anchor AA730 Kit



WIRED

(Up/Down Control + Chain Counter Readout)

Standard Package

- Sensor with 2m cable
- 2 X Magnet
- Base station
- Load sensing connectors
- Stowage Cradle
- Installation/Operation booklet
- Deck socket with 2m lead
- Socket Sealing Cap

AA710

Not included

- Plug-and-play sensor extension
- Sensor Holder (For horizontal windlasses)
- Wireless Range Extender

Additional connectors, consoles, base stations and antennas sold separately.

AA730

* Please refer to the installation manual for your specific installation requirements.

AA700 SERIES

FEATURES

- Full windlass control and chain counting
- Controls bow and stern thrusters independently and together
- Preset the length of rode to deploy
- Auto stop and docking alarm when the anchor is close to docking
- Works with rope/chain or all-chain rode
- Logs windlass operating hours for maintenance
- Easy installation and set up on most windlasses
- Plug and play sensor installation
- Console unit is shockproof, waterproof and will float
- High level wireless transmission security with unique ID
- 4 metres spiral cable
- Electrical protection against back-emf
- Rubber over-moulding for shock protection and grip
- Stowage cradle
- Operation in parallel with all AutoAnchor product, eg- toggle switches, foot switches or other control equipment
- Connect to DC, AC and Hydraulic systems
- Rugged cable and connectors



ANCHORING CONTROLS

Auto Anchor - AA320 Kit

Designed for single windlass single speed
Up/Down Control



2 Outputs
Single windlass single speed
Up/Down Control

2 Buttons Up/Down

Control Only
No AA Functionality

AA300 SERIES FEATURES

- Electrical protection against back-emf
- Ergonomic shape with rubber over-moulding for shock protection and grip
- Operation in parallel with all AutoAnchor products.
- Toggle switches, foot switches or other control equipment
- Connect to DC, AC and Hydraulic systems
- Rugged cable and connectors with:
 - Moulded plug and socket rated to IP67
 - 2m flying-lead from socket for better connectivity
 - Gold plated contacts on plug and socket to reduce corrosion

Auto Anchor - AA342 Kit

Designed for duel windlass single speed
Up/Down Control



4 Outputs
Duel windlass single speed Up/Down Control or
Single Windlass Fast/Slow Up/Down Control

2 Buttons Up/Down Port
2 Buttons Up/Down Starboard

Control Only
No AA Functionality

Standard Package



SCAN TO DISCOVER THE
FULL AUTO ANCHOR
RANGE

HEAVY DUTY HAND PENDANT

Heavy Duty Hand Pendants are recommended for vessels anchoring multiple times a day.

Heavy Duty - 2 Button Kit



Standard Package

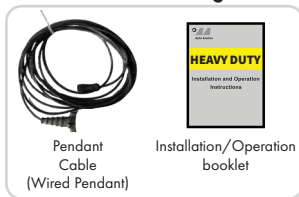

2 Outputs + Emergency Stop
2 Buttons Single Speed Up/Down
Available in wired and wireless versions
Control Only No AA Functionality

FEATURES

- Instantaneous action switches
- Dust-proof rubber/rubber-protected buttons/clamping screw adjustment sleeves
- IP 65 Protection according to CEI EN 60529
- Easy installation and easy (flexible/push-pull) connection of the switches
- Ergonomic and shock-resistant housing

Heavy Duty - 4 Button Kit



Standard Package

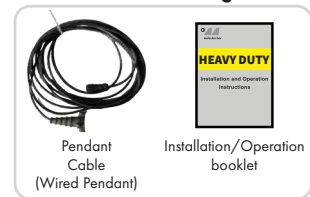

4 Outputs + Emergency Stop
4 Buttons Two Speed Up/Down
Available in wired and wireless versions
Control Only No AA Functionality

FEATURES

- 2 Speed options
- Instantaneous action switches
- Dust-proof rubber/rubber-protected buttons/clamping screw adjustment sleeves
- IP 65 Protection according to CEI EN 60529
- Easy installation and easy (flexible/push-pull) connection of the switches
- Ergonomic and shock-resistant housing

ANCHORING CONTROLS



FOOTSWITCHES

Heavy duty **footswitches** with marine grade covers and hard wearing U.V stabilized neoprene boot and each unit is supplied with instructions and fitting screws. Suitable for 12 and 24 volt applications, nickel plated copper contacts provide corrosion free operation. Available in multiple finishes.

Heavy-Duty Deck Foot Switch



Cover Variations



Available in single speed and two speed versions.

FEATURES

- Compatible with DC, AC and Hydraulic windlasses with control cabinets
- 1 Up Switch and 1 Down Switch
- Open contact, 150 Amps continuous rating
- Made from UV-stabilized ABS Plastic
- Nickel-plated copper contacts
- Strong Hinged Cover to prevent accidental operation

Heavy-Duty Deck Foot Pedal Switch



FEATURES

- Compatible with DC, AC and Hydraulic windlasses with control cabinets
- 2-pedal type
- Thermoplastic enclosure
- Small flat design
- Wiring compartment
- Micro switches (1-pole change-over contact per pedal) for current load up to 5 A

Remote Up/Down Control



FEATURES

- Allows simple remote operation of all windlasses from the helm, flybridge, or cockpit.
- Modern and sleek design, making it easy to install and use.
- Manufactured from durable marine-grade materials to withstand harsh marine environments.
- Fitted with power indicator lights for easy monitoring.
- Available in both 12V and 24V DC, suitable for various power systems.



Muir Mega Range

Established in 1968, Muir has become a dominant force in anchoring and mooring technology, recognised today as the anchoring system choice for a large variety and size of luxury motor and sail yachts.

Muir design and manufacture one of the largest ranges of anchoring and mooring systems for vessels up to 150 metres.

Muir have designed and produced anchoring and mooring equipment having set Industry Standards and benchmarks over many years. Continued investment in research and development, design and innovation, keeps Muir at the forefront of the yachting industry. The development of high power to weight ratio equipment with the combination of highly efficient planetary drive gears, medium to high pressure hydraulics, one, two or variable speed AC electric drives will achieve the ideal anchoring system to suit your vessel.

Muir surpass or meet the world's most stringent classification requirements including ABS, LRS, DNV, BV, NKK, GL, CCS, RINA, RRR, RMSR and comply with MCA and USL codes.

Muir running gear is available in polished 316L stainless steel, manganese bronze, chromed bronze and aluminium bronze.

316L polished stainless steel anchor windlasses and mooring capstans of all sizes are being manufactured in larger volumes today resulting in increased affordability.

A Muir anchoring system provides long term reliability, durability and dependability.

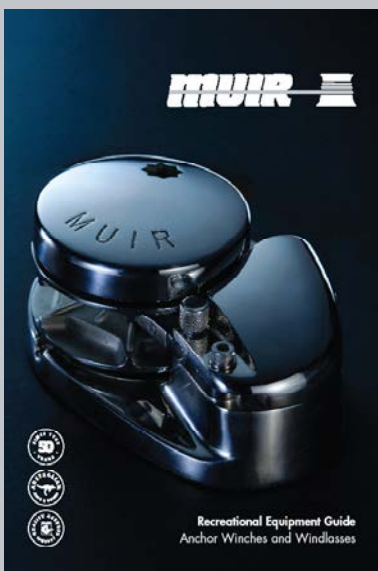

Muir Recreational Range

Selecting the appropriate windlass and ground tackle for your vessel and application ensures efficient deployment and retrieval of your anchor irrespective of anchoring or weather conditions. An undersized windlass may well compromise the safety of your vessel and crew. Choosing the right one should prevent costly repairs and damage.

When selecting a windlass there are a number of factors that need to be considered: vessel type, length and displacement, anchor and chain size, windage and the anchoring environment.

A windlass is often exposed to harsh elements therefore it is important to consider the materials and components it is manufactured from. Muir windlasses incorporate high quality components including chromed bronze and high quality marine grade 316 Stainless Steel running gear, stainless steel drive shafts and marine coated alloy housings, to ensure strength, durability and long term usage.

A powered windlass with some form of manual operation or override is always a wise choice and ensures peace of mind that the anchor can be retrieved if power failed or in an emergency. The type and style of windlass you select will depend on the depth of the chain locker, the fore deck layout, power options and personal preference.

Muir products are sold, serviced and supported worldwide.



AUSTRALIA • EUROPE • USA • ASIA • PACIFIC •

Copyright notice and disclaimer

Copyright in this publication is owned by Muir Engineering Group Pty. Ltd.

Information in this publication is intended for general information only and does not constitute professional advice and should not be relied upon as such.

No representation or warranty is made as to the accuracy, reliability or completeness of any information in this publication.

Readers should make their own enquiries and reach to the nearest distributor before acting on or relying upon any of the information provided.

Images used within this publication remain the property of the copyright holders.

Cover image supplied courtesy of Austal -

The RAN's Evolved Cape-class Patrol Boat, designed and constructed by Austal and featuring Muir anchor winches. VRC13000.

Muir reserves the right to alter specifications without notice. All rights reserved. While all due care and attention has been taken in the preparation of this catalogue no responsibility shall be taken for errors or omissions.

THIS CATALOGUE SHOULD NOT BE USED FOR INSTALLATION PURPOSES

Any reference to MUIR or MUIR'S in this catalogue implies MUIR ENGINEERING GROUP PTY. LTD.

©2021 Muir Engineering Group Pty. Ltd.

The Muir Quality Management System is certified as being in conformity with ISO9001.





Head Office

100 Browns Road, Kingston
Tasmania, Australia 7050

T +61 (0) 3 6229 0600
F +61 (0) 3 6229 7030
E sales@muir.com.au

Queensland Branch

15/75 Waterway Dve, Coomera
Queensland, Australia 4209

T +61 (0) 7 5555 2222

New South Wales Branch

Unit D6, 1 Campbell Pde, Manly Vale New
South Wales, Australia 2093

T +61 (0) 2 9949 4084

Since 1968.
Built to last.



muir.com.au