

MILLER WINDLASS

CAPSTANS
WINDLASSES
DEVIL CLAWS
CHAIN STOPPERS
DECK HARDWARE
ANCHOR ROLLERS
CRANES & DAVITS
ANCHORS & CHAIN
ELECTRIC CONTROLS
SYSTEM ACCESSORIES
CHAIN COMPRESSORS
3D MODELLING CAPABILITIES
COMPLETE ANCHORING SYSTEMS

Mega Yacht Equipment
Anchor Winches and Windlasses



Image supplied courtesy of Austal Australia



Since 1968. Built to last.

For over a century the Muir name has been synonymous with ship building and marine engineering, and for over 55 years Muir has been designing and crafting anchor winches and anchoring systems that are the benchmark for performance, quality and innovation.

Our reputation is built on the back of the hard work of our founder, Robert John Muir, who grew up in the portside suburb of Battery Point, down the road from the “Shipwright’s Arms” Hotel. Hailing from a family of seafarers and shipwrights, John was destined from a career in the marine industry, and it was next to his father’s boat building business, that he developed the very first Muir anchor winches. The advice from his father, Jock Muir, continues to prove pivotal in building and maintaining the reputation Muir carries to this day:

“MAKE SURE THE WINCH YOU DESIGN AND BUILD IS STRONGER THAN THE DECK IT’S BOLTED DOWN TO.”

Our team remain committed to honouring this founding vision in our Tasmanian production facility and we now craft anchoring systems for a wide range of vessels.

From a 5-metre vessel to the world’s largest mega yachts, Muir products are requested around the globe and used by leading recreational, mega yacht and commercial maritime brands including Feadship, Luerssen, Incat, Austal, Damen, Moonen, Riviera, Maritimo, and Telwater.

In support of our equipment, our global network of experienced sales managers and service groups combined with a trusted international distribution network, ensures that we can deliver quality anchoring systems and spares to you, no matter what size your vessel is.

To this day, Muir remains an Australian, family owned business, and is the only remaining specialised Anchoring Systems manufacturer.

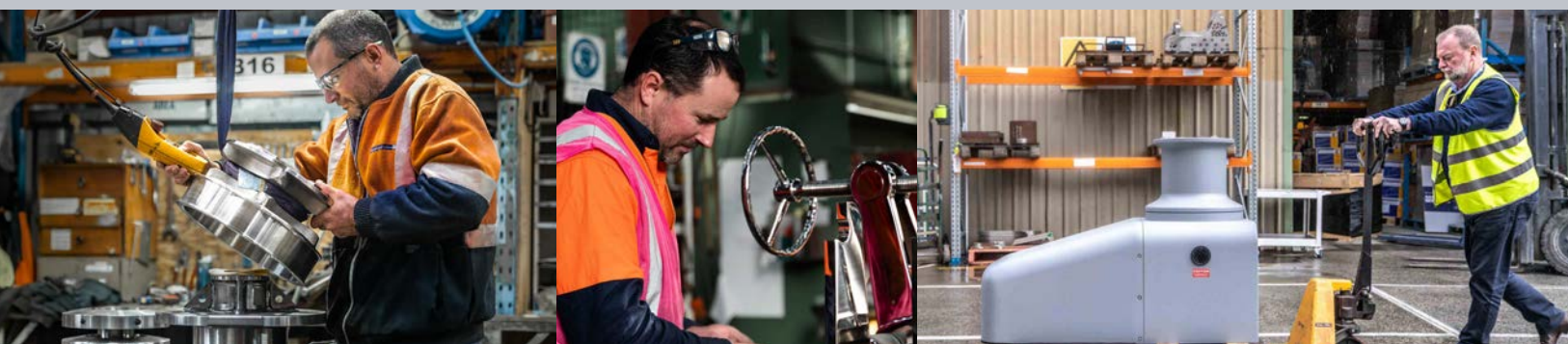

Contents

PRODUCT INFORMATION	PAGE
Vertical Windlasses	2
Horizontal Windlasses	3
Vertical Mooring and Decking Capstans	3
Technical Information	4
Environmental Commitment Statement	5
Windlass Selection Guide	6-7

CAD DRAWINGS & SPECIFICATIONS

VRC4500	8-9
VRC6000	10-11
VRC8000	12-13
VRC11000	14-15
VRC13000	16-17
VRC15000	18-19
VRC18000	20-21
VRC20000	22-23
VRC22000/23000	24-25
VRC24000/26000	26-27
HR5000	28
HR6000	29
HR8000	30
HR11000	31
HR15000	32
HR22000/24000/26000	33
VC4500	34
VC6000	35
VC8000	36
VC13000	37
VC18000	38
VC20000	39
VC22000	40
VC24000	41

ANCHORING SYSTEM ACCESSORIES

Chain Stoppers & Anchoring Systems	42-43
Chain Compressors	44
Curved Chain Pipe Rollers	45
Turning Block Fairlead	46
Integrated Bollard Capstan	46
Anchoring Accessories	47-48
Autoanchor Windlass Controls & Chain Counters	49
Complete Anchoring Systems	50-51
Glossary of Terms	54

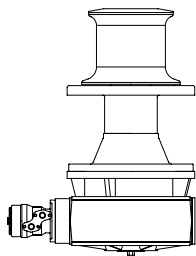
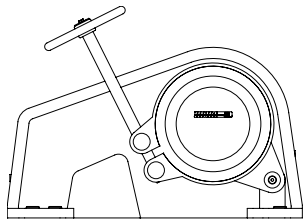
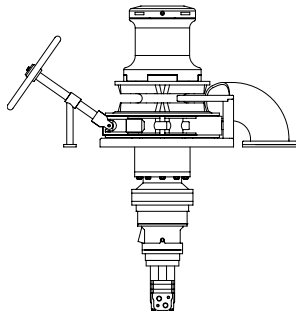

MEGA YACHT ANCHORING SYSTEMS

VERTICAL WINDLASSES – VR/VRC

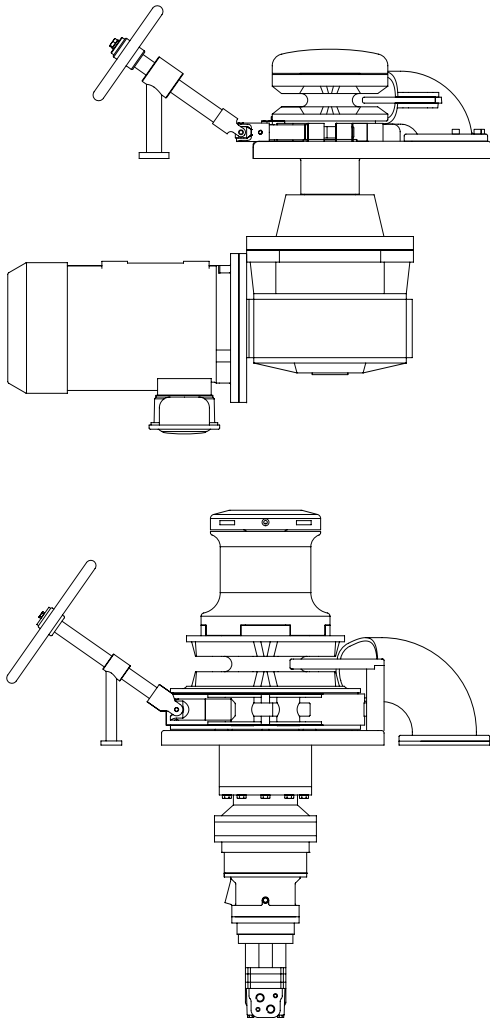

Vertical windlass models have a main vertical shaft and horizontal gypsy, and are available in two configurations. VRC has a gypsy and independent capstan, whilst the VR has gypsy and low profile top only. The low profile VR is available on all models.

The vertical configuration allows for single and twin installations with the advantage of installing the windlasses in various positions. This facilitates the positioning of anchor pipes and spurling pipes. In some cases it may be preferable to install windlasses closer to the centre line or further apart.

Integral VR/VRC 4500, 6000, 8000, 11000 designs incorporate extended deck plates for the brake band location and integral chain pipe. The windlass and chain pipe are supplied as a complete assembly on one single base, either as single units or in mirror image.

A range of round base units offer flexibility of installing separate chain pipes or chain pipe rollers. A feature of the round base models is the heavy duty chain stripper.

Muir vertical windlass design innovation enables disassembly of the running gear above the deck plate and removal of the drive gear below deck leaving the deck plate and chain pipe/roller intact.

All vertical windlasses have a self-aligning gearbox adaptor that reduces installation time and allows the gearbox and motor to be installed directly onto the windlass drive in any radial position. This alleviates distortion between the deck plate and gearbox flange and a sealed shaft protects the transmission below deck.

Vertical windlasses require less deck space than a horizontal windlass and vertical capstans have operational advantages for mooring purposes due to the radial scope of the lead for mooring lines. For servicing and lubrication all running gear is readily accessible.

Planetary drives are available on vertical models with AC and Hydraulic brake motors fitted, right angle drives are available for all installations throughout the ranges. AC motors require to be supported to the deck structure.

Hydraulic drives are fitted with counter balance valves to prevent runback. Heavy-duty concealed dog clutch drives on larger models ensure positive drive at all times, whilst hand wheels and brake bands to chain gypsies provide infinite control of braking.

Windlasses with round base plates have installation flexibility of rotating brake band and hand wheel in any position.

Up to 180° chain wrap on vertical designs ensures optimum utilisation of the chain gypsy pockets.

Independent operation of the capstan and gypsy is achieved by declutching the capstan. The full range is available with an extended capstan shaft for split positioning of the gypsy below deck and capstan above deck for mooring and line hauling purposes.

Options - Vertical Windlasses

- Polished bronze finish
- Polished stainless steel finish
- Two-speed motors and variable speed controls
- Inline or 45° universal brake handwheel control
- Increased working speed
- Mirror Image
- Fluted capstans for line grip
- Variable brake band positioning to optimise deck space and handwheel location
- High pressure hydraulic motors standard on larger models and optional on other models
- Hydraulic and electric power packs and controls
- Raised bases and plinths for equipment
- Chain pipe with nylon or bronze rollers
- Control cabinets for electric AC models for in one or two speed or variable speed drives (VFD'S)
- Windlass controls
- 700V DC input to cabinet
- Painted and commercial finishes

Standard Features

- Single Speed Reversible motor
- Independent operation of gypsy and capstan
- Easy servicing: disassemble from top and bottom without disturbing deck plate fastenings
- Chain pipe
- Corrosion resistant construction
- Knurled or Fluted capstan for line grip
- High tensile stainless steel drive shaft
- Gearbox and motor can be rotated to fit confined space below deck
- Heavy duty totally sealed high efficiency in line or right angle gearbox
- Dog clutch (except 4000 / 4500) and clutch handle
- Brake band and brake handle
- AC torque limiter supplied with all anchor windlass models from 6000 and above windlasses (in special cases the torque limiter may not be required when variable frequency drives are installed (VFD'S))
- ISO standard gypsy design for smooth operation
- Off - the shelf gearboxes and motors for readily available parts
- Total project design retention for future supply of spare parts

HORIZONTAL WINDLASSES - HR

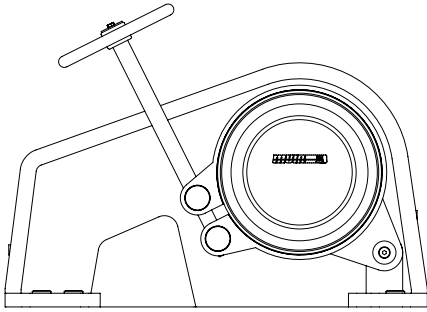

Options - Horizontal Windlasses

- White epoxy enamel housing with polished bronze gypsy and capstan
- White epoxy enamel housing with polished stainless steel gypsy and capstan
- Twin gypsies
- Twin capstans
- Fluted capstan for line grip
- Vertical capstans
- 2 speed motor or variable speed controls
- Protective weatherproof cover
- Increased working speed
- High pressure motors available on request
- Various colours available for housing finish
- Hydraulic and electric power packs and controls
- Control cabinets for electric AC models for in one or two speed or variable speed drives (VFD'S)
- 700V DC 690V AC options

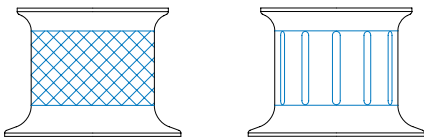

Options - Capstans

- Fluted Capstan for line grip
- Polished bronze finish
- Polished stainless steel finish
- Tall Drum models
- 2 speed motors and variable speed controls
- Increased working speed
- Raised bases and plinths for capstans
- High pressure motors available on request and standard on some larger models
- Hydraulic and electric power packs and controls
- Control cabinets for electric AC models for in one or two speed or variable speed drives (VFD'S)
- Integrated mooring bollard
- 700V DC/690V AC options

Horizontal windlasses have the main drive shaft with single or dual chain gypsies and capstans driving through a single gear drive. This drive mechanism is totally enclosed in the windlass casing above deck, which is an advantage when space below deck is at a premium.

A horizontal windlass gypsy increases the height of fall of the chain into the chain locker where depth may be critical. Positioning of the gypsy and chain pipe requires the location of the horizontal windlass above the chain-locker and the lead from the bow roller or hawser pipe determines the location.

Gypsy centres to windlass or vessel centre line can not be varied. All running gear can be serviced and lubricated without interfering with the windlass casing or chain pipes. Independent operation of capstan(s) and gypsies by declutching the drive. Operation of the horizontal capstan in the standing position for mooring and line handling can be advantageous.

Horizontal windlass casings are fabricated SS 316 with white gloss finish. All Muir horizontal windlasses have heavy-duty clutch drives with handwheel and brake bands to gypsies for infinite control of braking.

A vertical capstan option on top of the windlass can facilitate mooring and line handling when horizontal capstans can not be fitted due to limited deck space.

Standard Features

- Single capstan to port, gypsy to starboard
- Reversible motor
- Independent operation of gypsy and capstan
- Heavy Duty totally sealed gearbox with ground worm drive and tapered roller bearings in oil bath
- All lubrication points are external
- White epoxy enamel housing with chrome bronze or SS 316 gypsy and capstan.
- Knurled capstan for line grip
- Stainless steel shaft (High tensile)
- Dog Clutch and clutch handles on models 6000 and above
- Brake band and brake handles polished 316 stainless steel
- Chain pipes
- Chrome bronze or SS 316 gypsy and capstan

NOTE: Maximise angle of chain wrap up to 180° to improve windlass performance
Minimum wrap is 120°

VERTICAL MOORING AND DOCKING CAPSTANS - VC

Muir capstans provide reliable and heavy duty operation for mooring and docking. Usually located on the aft deck and amidships to assist in the mooring or docking of the yacht, they can be operated by remote control or foot switches for hands free operation.

Capstans can be supplied with inline or 90° gear drives in hydraulic or electric power for the most compact installation.

Capstans can be serviced with the deck plate intact from top and bottom side. Capstan selection should be considered with warping line sizes and flexibility of warp.

Standard features

- Reversible motor
- Easy servicing: disassemble from top and bottom without disturbing deck plate fastenings
- Chromed bronze or 316L polished stainless steel
- Knurled capstan for extra line grip
- Large capstan drums for increased line hold
- Stainless steel drive shaft
- Gearbox can be rotated to fit confined space below deck
- Heavy duty totally sealed high efficiency in line or right angle planetary drive gears on medium to larger models

MEGA YACHT ANCHORING SYSTEMS



IMPORTANT:

KW Power requirements: Power may be increased if required for special applications, pulls are indicated using motor kW sizes as in the catalogue specification.

On both windlasses and capstans it is advisable to maximise KW power on electric drives to optimise functionality, and to prevent the circuit breaker tripping under heavy load.

KW power requirements - may vary between planetary worm and gear drives.

Starting loads: the design of the preferred starting system is important, and it should be noted that the vessels generating capacity and requirements should be able to start the windlasses under load.

Mooring Capstans: Selection and sizing needs to consider high profile, large or heavy displacement craft and high wind conditions to be encountered while docking.

Model Numbers: Product model numbers are not necessarily indicative of the lift capacity.

CLASSIFICATION PERFORMANCE AND APPROVAL:

Classification Societies require a minimum speed of 9 metres/minute and Muir designs can be supplied with optional two-speed AC electric systems or variable speed drives (VFD's) for variable speed ranges generally up to 20 metres/minute in high speed.

Muir build to specific classification society requirements including ABS, LRS, DNV, NKK, BV, K.R, RINA, RRR, RMSR and CCS. All Muir equipment meets international standards including MCA and USL codes and CE

Requirements for electrical components. Muir recommend the windlass should have the capacity (pull) to retrieve all of the anchor and chain in a vertical lift with the anchor clear of the bottom.

We strongly recommend contacting your local Muir agent or Muir head office regarding specific classification requirements prior to selecting a windlass or mooring capstan model.

TECHNICAL INFORMATION

Muir has adopted the corporate policy of manufacturing and selling products which have the recognised standard of quality that satisfies customers throughout the effective life span of the product. It is therefore an essential requirement of this stipulated policy for Muir to produce and supply its customers with products which are suitable for their intended purpose, and which are in conformity with the relevant and agreed specification or contract.

The procedures outlined in our ISO9001 quality assurance manual describe how the quality system is designed to ensure that customer requirements are recognised and that consistent control of these requirements is established, implemented and maintained. Strict adherence to the policy stated above is a requirement of every aspect at Muir.

3D and AutoCAD drawings are available as digital files.

Running gear is bronze, aluminium bronze or 316L stainless steel and the main drive shaft, brake spindle, handwheels and fastenings are stainless steel.

On vertical models motor drives and gears below deck are finished in white gloss. Horizontal models have the motor and gearbox enclosed above deck.

Brake design on some models may not require use of chain stoppers or where distance between spurling pipe and gypsy is tight, however a heavy duty devil claw and snubber line arrangement must be used to eliminate loads off the windlass drive.

Heaters and thermistors are optional on AC motors.

Chain Gypsies are available to suit ISO, DIN 766 and Studlink marine chains. Custom designed windlasses for specialised installations can be supplied on request.

On placing an order we require a chain sample, including joining links and kenter shackles (if they are to be accommodated), so they can be matched to the chain gypsy and ensure correct fit.

Larger windlasses are mainly manufactured from stainless steel in polished or satin finishes.



MEGA YACHT ANCHORING SYSTEMS

ABBREVIATIONS

DC	Direct Current	lb	Pound
AC	Alternating Current	kg	Kilogram
HYD	Hydraulic	Min	Minute
gal	Gallons (US)	m	Metre
lt	Litres	mm	Millimetre
MPa	Megapascal	"	Inch
PSI	Pounds per square inch	' / ft	Feet

Displacement, Length, Type of Vessel (Motor Boat or Sail Yacht, Heavy or Light Displacement etc) and Windage of a vessel must be taken into consideration when selecting a windlass, anchor and chain. The particular classification societies equipment number for the particular vessel is also very important as it stipulates the recommended chain size (and length), anchor ðeight and other important information than needs to be considered. In addition, the vessels proposed use is important as it will differ depending on the application (short cruising in sheltered waters to extensive global cruising with exposure to all types of anchoring conditions).

Grab THE guide.



Scan here or visit beacons.ai/muir to get your copy.

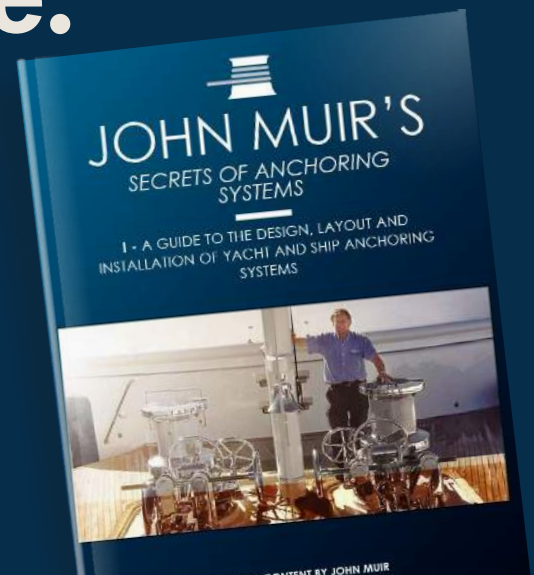

ENVIRONMENTAL COMMITMENT STATEMENT

At Muir Anchoring Systems, we are deeply committed to sustainability and environmental stewardship. Our dedication to protecting our planet is reflected in every aspect of our business operations. Here's how we demonstrate this commitment:

- 1. Renewable Energy:** We proudly source **100% of our energy** from renewable sources through the Tasmanian energy network. By harnessing the power of wind, water, and sun, we minimize our carbon footprint and contribute to a cleaner energy grid.
- 2. Solar Power:** Our commitment extends beyond the grid. Our headquarters features a state-of-the-art **rooftop solar array** that generates clean electricity. This solar installation not only powers our facility but also feeds surplus energy back into the grid.
- 3. Material Recycling:** We meticulously sort and recycle a **majority of our scrap materials** generated during our manufacturing processes. By doing so, we reduce waste and promote circular economy principles.
- 4. Component Reuse and Recycling:** Sustainability is about more than just recycling; it's also about reusing valuable resources. At Muir, we **reuse and recycle returned second-hand components** whenever possible. By extending the lifespan of these components, we minimize waste and conserve raw materials.
- 5. Energy-Efficient Drivetrains:** Our commitment to efficiency extends to the vessels that use our anchoring and mooring systems. We collaborate with shipbuilders and yacht manufacturers to integrate high-efficiency drivetrains. These advanced propulsion systems reduce fuel consumption and emissions, ensuring a greener maritime industry.

Reducing Embodied Energy: Our focus on sustainability not only benefits the environment but also has a positive impact on the **embodied energy** within our components. By reusing materials and minimizing waste, we decrease the energy required to produce new components. This reduction in embodied energy contributes to a more sustainable product lifecycle.

Ongoing Energy Consumption: Beyond the initial manufacturing phase, our energy-efficient systems continue to operate with minimal energy consumption. Whether it's our anchoring solutions or mooring systems, we prioritize designs that optimize energy usage, benefiting both our customers and the environment.

By choosing Muir, you're not only investing in topquality anchoring and mooring systems but also supporting a company that prioritizes the health of our planet. Together, we sail toward a more sustainable future.

For more information about Muir Anchoring Systems and our commitment to environmental responsibility, please visit our official website.

MEGA WINDLASS SELECTION GUIDE

MODEL			STUD CHAIN SIZE (mm)															
			12.5	14	16	17.5	19	20.5	22	24	26	28	30	32	34	36	38	+
Vertical Windlasses																		
VR/VRC 4500/5000	Page 6-7	U2	●	●														
		U3	●															
VR/VRC 6000	Page 8-9	U2	●	●	●													
		U3	●	●														
VR/VRC 8000/11000	Page 10-13	U2			●	●	●	●	●									
		U3			●	●	●											
VR/VRC 13000/15000	Page 14-17	U2			●	●	●	●	●	●								
		U3			●	●	●	●	●	●								
VR/VRC 18000	Page 18-19	U2								●	●	●						
		U3								●								
VR/VRC 20000/21000	Page 20-21	U2								●	●	●	●					
		U3								●	●	●						
VR/VRC 22000/23000	Page 22-23	U2									●	●	●	●	●	●	●	
		U3									●	●	●	●				
VR/VRC 24000/26000	Page 24-25	U2													●	●	●	
		U3													●	●	●	
VR/VRC 32000/40000	On Request	U2																●
		U3																●
Horizontal Windlasses																		
HR 4500/5000 (SGC 0)	Page 26		●	●														
HR 6000 (SGC 1)	Page 27	U2	●	●	●													
		U3	●	●														
HR 8000 (SGC 2)	Page 28	U2			●	●	●											
		U3			●	●												
HR 11000 (SGC 3)	Page 29	U2			●	●	●	●										
		U3			●	●	●											
HR 15000 (SGC 4)	Page 30	U2						●	●	●	●							
		U3					●	●	●	●								
HR 22000+ (SGC 5+)	Page 31	U2									●	●	●	●	●	●	●	●
		U3									●	●	●	●	●	●	●	●
Powered Capstans																		
VC 3500	Page 32																	
VC 4500	Page 32																	
VC 6000	Page 33																	
VC 8000/11000	Page 34																	
VC 13000/15000	Page 35																	
VC 18000	Page 36																	
VC 20000	Page 37																	
VC 22000/24000	Page 38-39																	
VC 26000/32000	On Request																	

MEGA YACHT ANCHORING SYSTEMS

MUIR RESERVES THE RIGHT TO ALTER SPECIFICATIONS WITHOUT NOTICE, AND THIS CATALOGUE SHOULD NOT BE USED FOR INSTALLATION PURPOSES.

SPECS IN CATALOGUE ARE INDICATIVE ONLY AND MAY VARY FOR A SPECIFIC PROJECT.

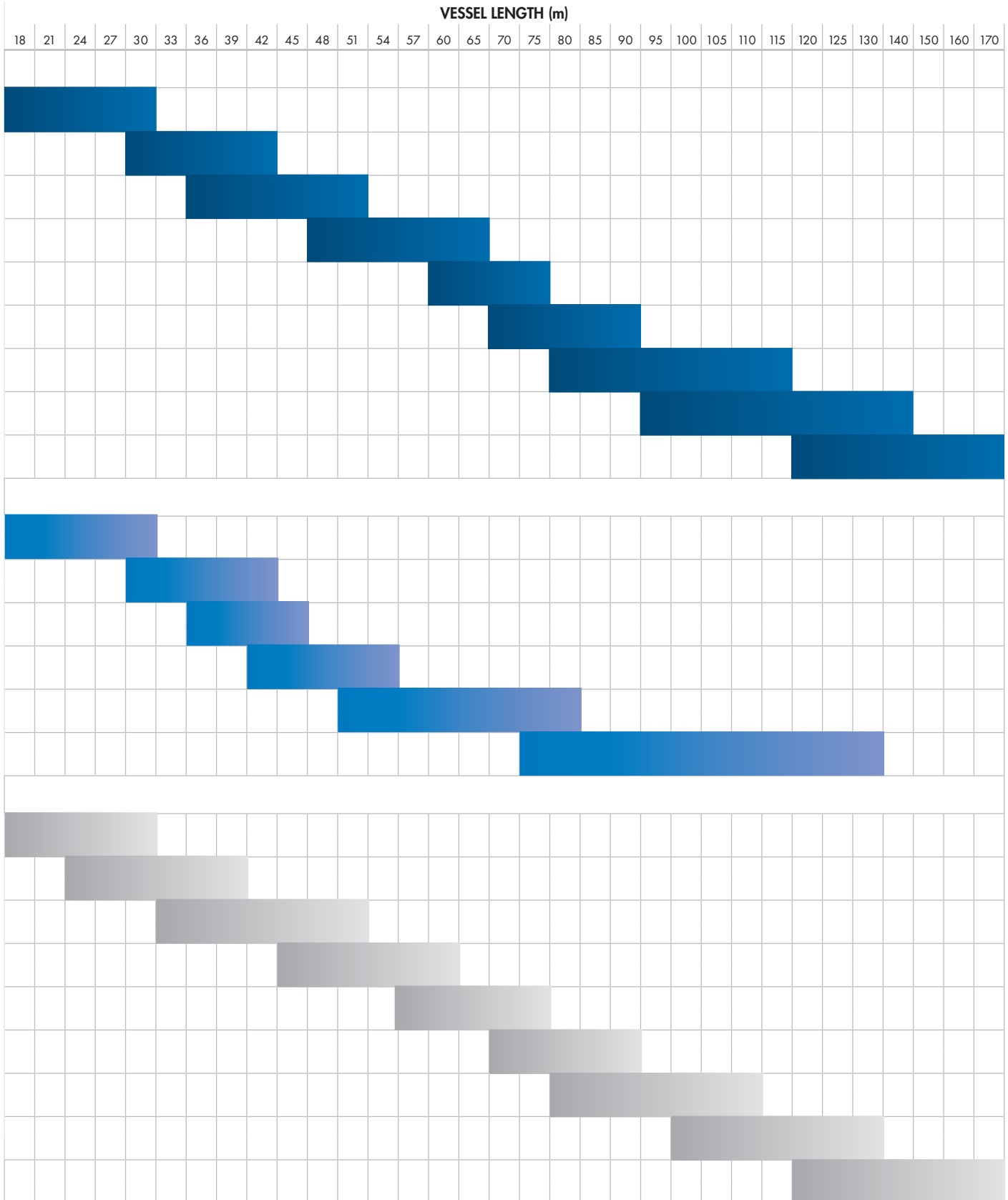

VR/VRC 4500

Vertical Windlass

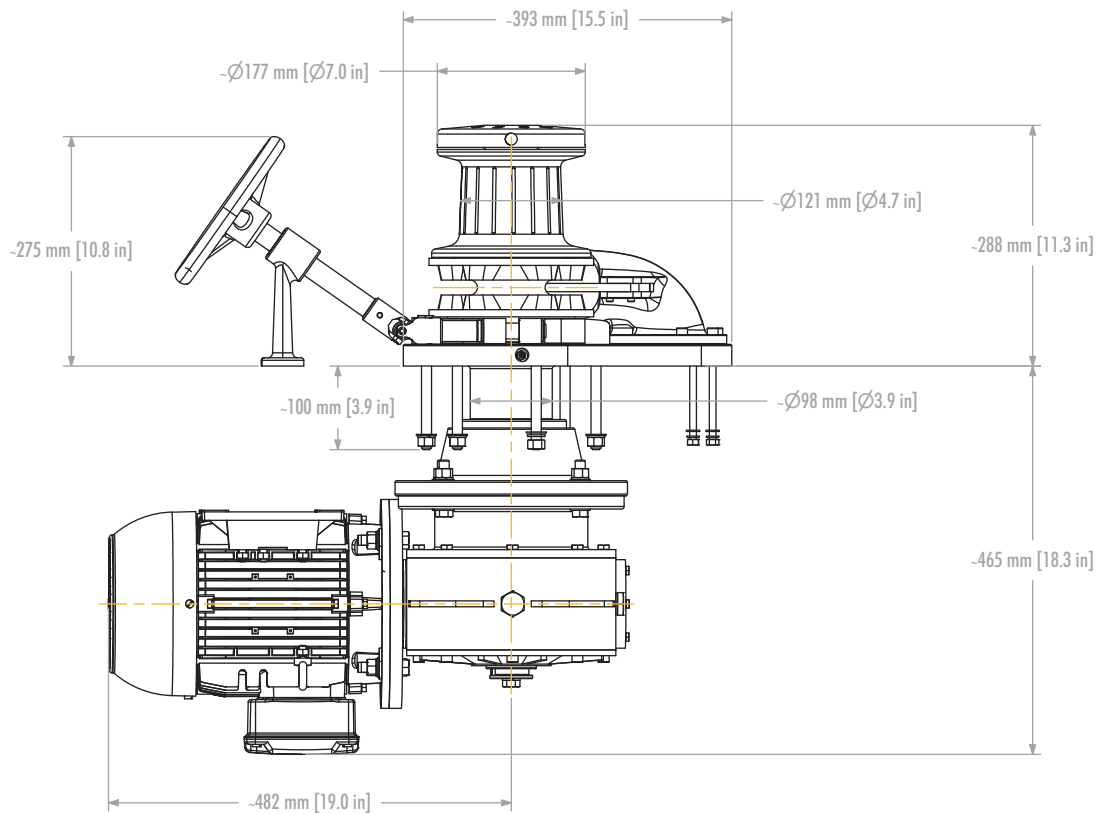

PERFORMANCE CRITERIA

MODEL	VRC4500	VRC4500	VRC4500	VRC4500
Maximum Pull (kg/lb)	2300 / 5060	2300 / 5060	2300 / 5060	2300 / 5060
Continuous Pull (kg/lb)	950 / 2090	1050 / 2310	1050 / 2310	1600 / 3520
Recommended Minimum Speed (m/pmin - f/pmin)	14 / 46	10 / 33	10 / 33	10 / 33
Maximum Recovery High Speed (m/pmin - f/pmin)		20 / 66	20 / 66	20 / 66
Power Supply	24VDC	3PH / 50HZ	3PH / 60HZ	HYDRAULIC
Input Power (kW)	3/3.5	4	4	
Hydraulic Flow (l/pmin-USgpm)				26 / 6.9
Maximum Flow (l/pmin-USgpm)				52 / 13.8
Pressure (bar/PSI)				175 / 2537
Maximum Pressure (bar/PSI)				200 / 2900
Chain Size				
Short link up to	16mm / 5/8"	16mm / 5/8"	16mm / 5/8"	16mm / 5/8"
Stud link up to	14mm U2	14mm U2	14mm U2	14mm U2
Brake Size	150mm / 6"	150mm / 6"	150mm / 6"	150mm / 6"
Average Weight (kg/lb)	125 / 275	155 / 341	155 / 341	113 / 248

(Note - Deduct 2kg / 4.4lb for VR models)

VR/VRC 4500

Vertical Windlass

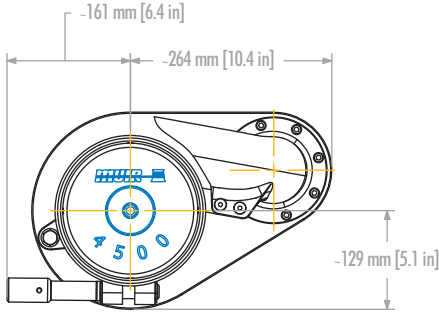

Integral Base Standard Brake with Chain Pipe
*Roundbase option available for extra cost

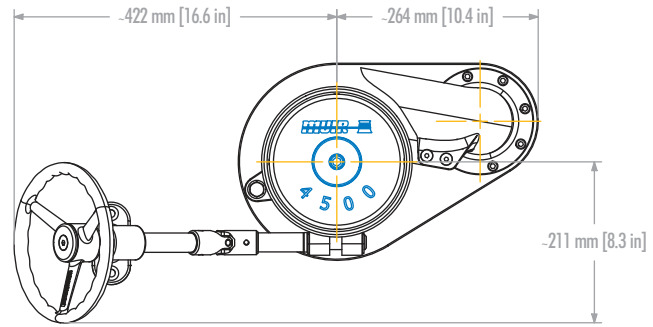

Integral Base 35° Brake with Handwheel and Chain Pipe
*Roundbase option available for extra cost

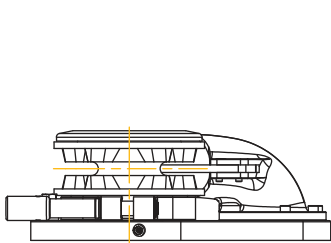

VR Low Profile Integral Base Standard Brake

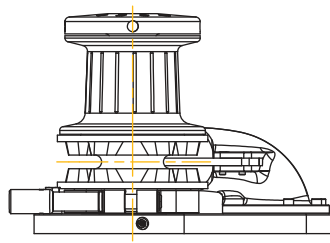

VRC Integral Base Standard Brake

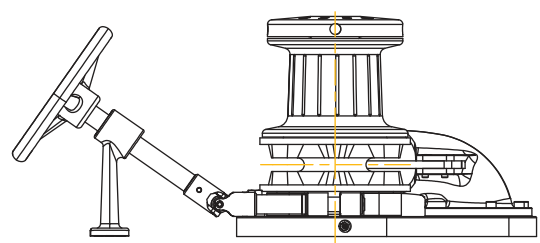

VRC Integral Base 35° Brake/Handwheel

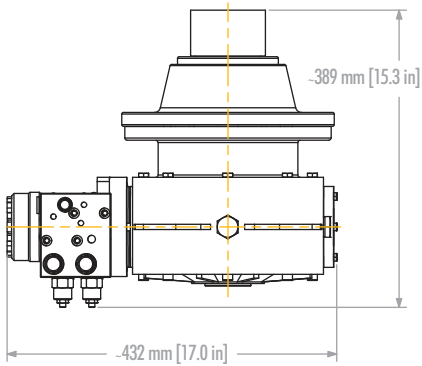

Right Angle Hydraulic Worm Drive

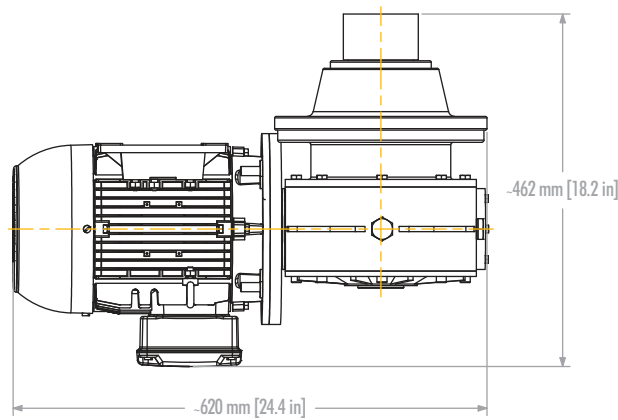

Right Angle Electric Worm Drive

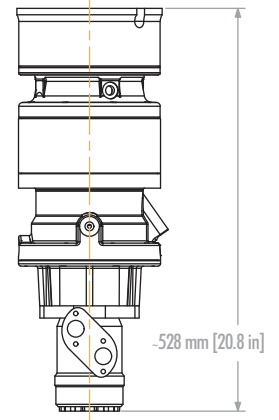

Inline Hydraulic Planetary Drive
*option available for extra cost

VR/VRC 6000

Vertical Windlass

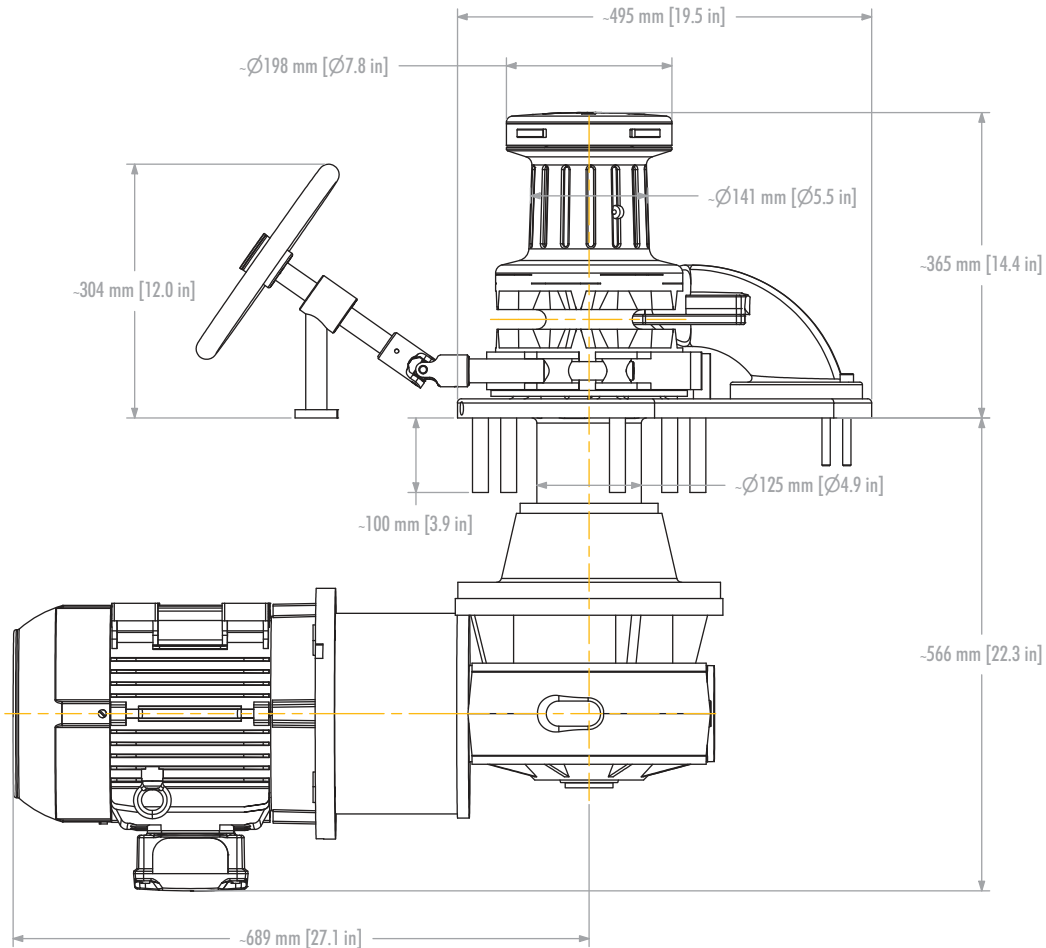

PERFORMANCE CRITERIA

MODEL	VRC6000	VRC6000	VRC6000	VRC6000
Maximum Pull (kg/lb)	2600 / 5720	2900 / 6380	2900 / 6380	2900 / 6380
Continuous Pull (kg/lb)	1300 / 2860	1430 / 3146	1430 / 3146	2138 / 4703
Recommended Minimum Speed (m/pmin - f/pmin)	15 / 50	11 / 36	14 / 33	10 / 33
Maximum Recovery High Speed (m/pmin - f/pmin)		22 / 72	22 / 72	20/66
Power Supply	24 VOLT	3PH / 50HZ	3PH / 60HZ	HYDRAULIC
Input Power (kW)	3.5	5.5	5.5	
Hydraulic Flow (l/pmin-USgpm)				28 / 7.4
Maximum Flow (l/pmin-USgpm)				56 / 14.8
Pressure (bar/PSI)				175 / 2537
Maximum Pressure (bar/PSI)				200 / 2900
Chain Size				
Short link up to		16mm / 5/8"	16mm / 5/8"	16mm / 5/8"
Stud link up to		16mm U2	16mm U2	16mm U2
Brake Size		230mm / 9"	230mm / 9"	230mm / 9"
Average Weight (kg/lb)		245 / 539	245 / 539	176 / 387

(Note - Deduct 2kg / 4.4lb for VR models)

High Pressure 240 BAR
3600PSI optional

VR/VRC 6000

Vertical Windlass

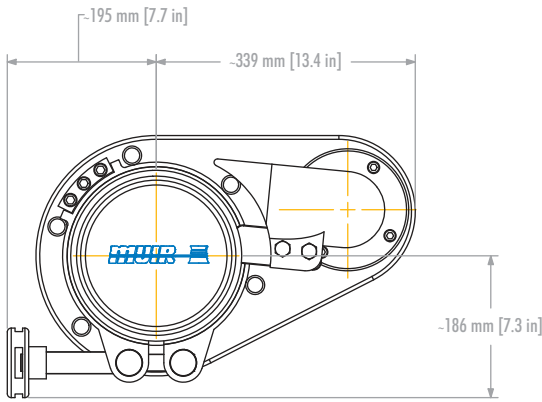

Integral Base Standard Brake with Chain Pipe
*Roundbase option available for extra cost

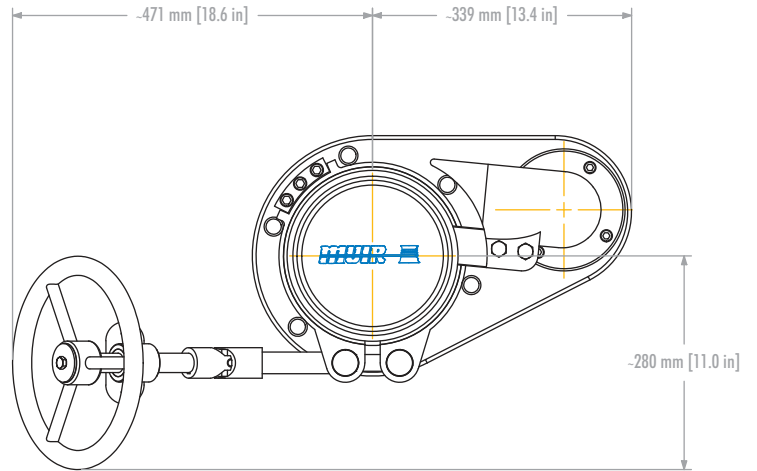

Integral Base 35° Brake with Handwheel and Chain Pipe
*Roundbase option available for extra cost

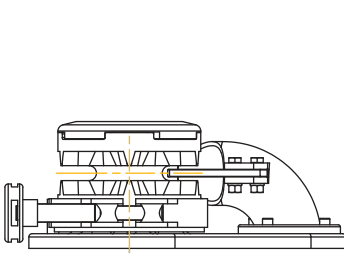

VR Low Profile Integral Base Standard Brake

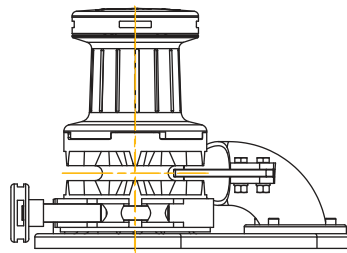

VRC Integral Base Standard Brake

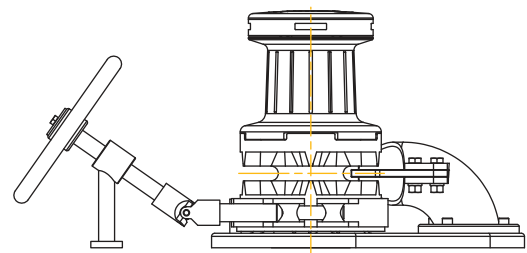

VRC Integral Base 35° Brake/Handwheel

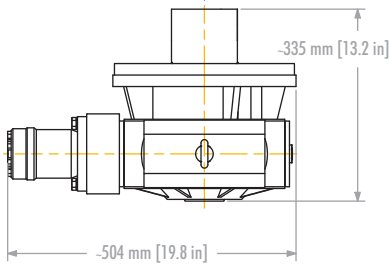

Right Angle Hydraulic Worm Drive

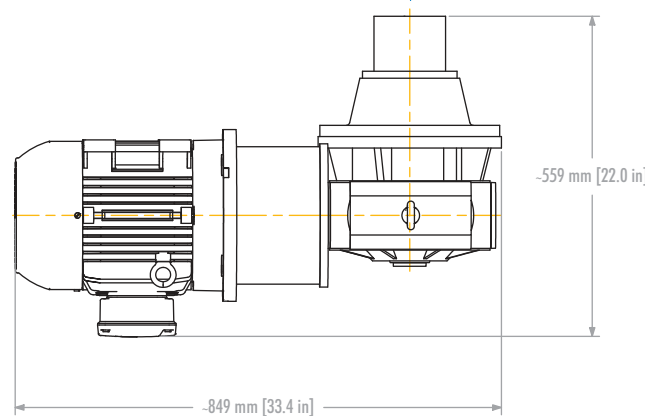

Right Angle Electric Worm Drive

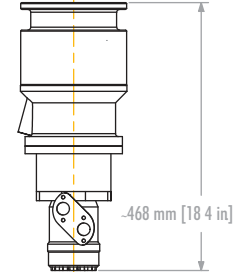

Inline Hydraulic Planetary Drive
*option available for extra cost

VR/VRC 8000

Vertical Windlass

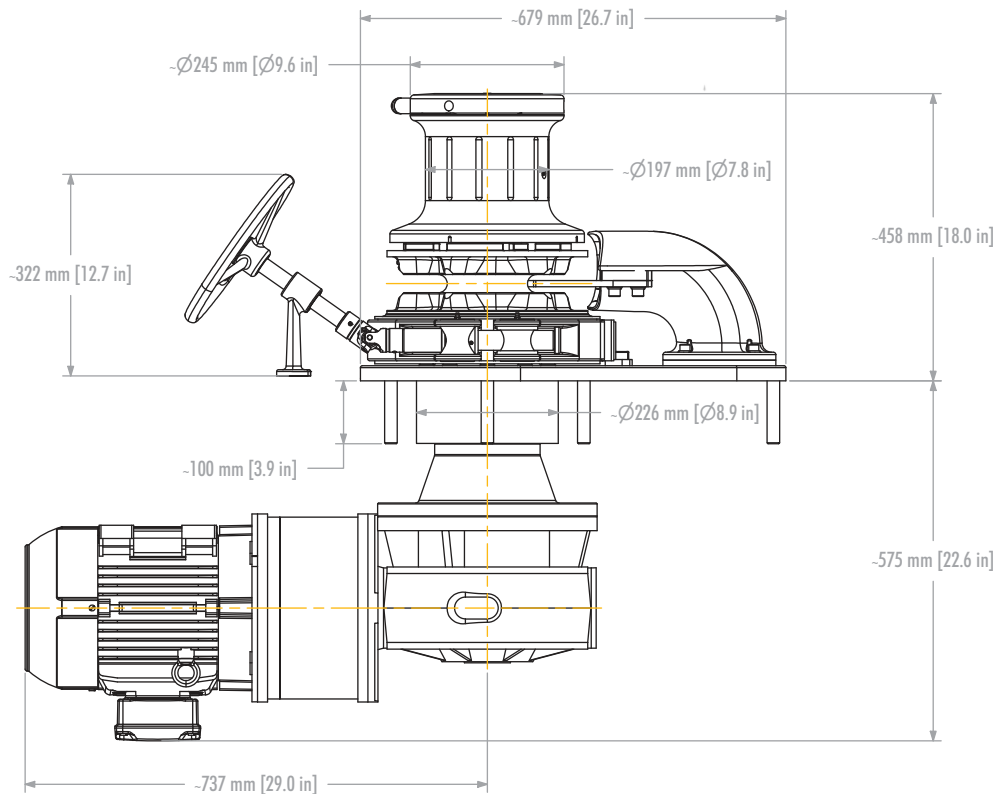

PERFORMANCE CRITERIA

MODEL	VRC8000	VRC8000	VRC8000
Maximum Pull (kg/lb)	3800 / 8360	3800 / 8360	3800 / 8360
Continuous Pull (kg/lb)	2200 / 4840		2900 / 6380
Recommended Minimum Speed (m/pmin - f/pmin)	10 / 33	10 / 33	10 / 33
Maximum Recovery High Speed (m/pmin - f/pmin)	20 / 66	20 / 66	20 / 66
Power Supply	3PH / 50HZ	3PH / 60HZ	HYDRAULIC
Input Power (kW)	5.5	5.5	
Hydraulic Flow (l/pmin-USgpm)			28 / 7.4
Maximum Flow (l/pmin-USgpm)			56 / 14.8
Pressure (bar/PSI)			175 / 2537
Maximum Pressure (bar/PSI)			200 / 2900
Chain Size			
Short link up to	19mm	19mm	19mm
Stud link up to	19mm U2/17.5mm U3	19mm U2/17.5mm U3	19mm U2/17.5mm U3
Brake Size	356 / 14	356 / 14	356 / 14
Average Weight (kg/lb)	325 / 715	325 / 715	270 / 594

High Pressure 240 BAR
3600PSI optional

VR/VRC 8000

Vertical Windlass

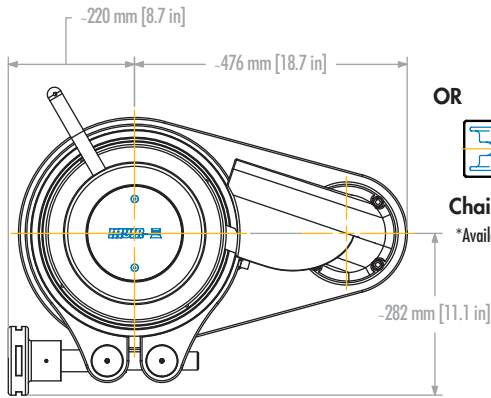

OR



Chain Pipe Roller
*Available on round base version

Integral Base Standard Brake with Chain Pipe
*Roundbase option available for extra cost

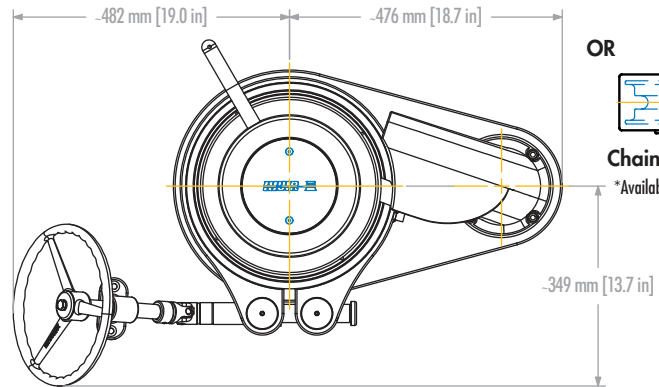

OR



Chain Pipe Roller
*Available on round base version

Integral Base 35° Brake with Handwheel and Chain Pipe
*Roundbase option available for extra cost

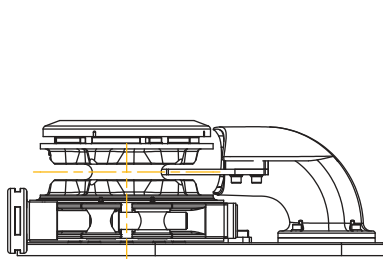

VR Low Profile Integral Base Standard Brake

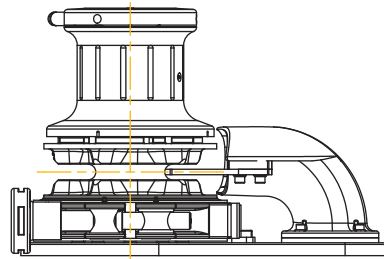

VRC Integral Base Standard Brake

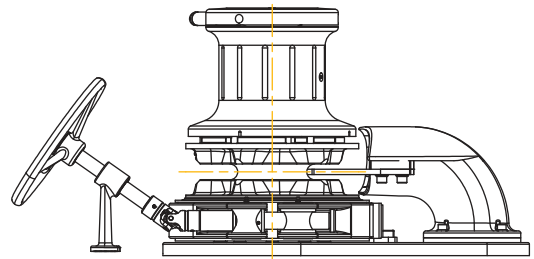

VRC Integral Base 35° Brake/Handwheel

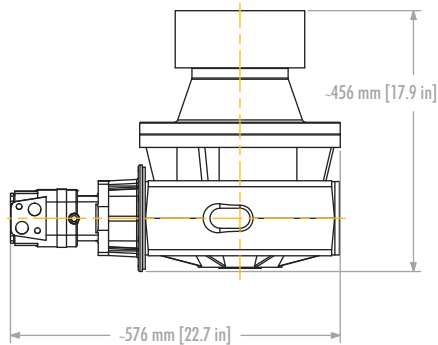

Right Angle Hydraulic Worm Drive

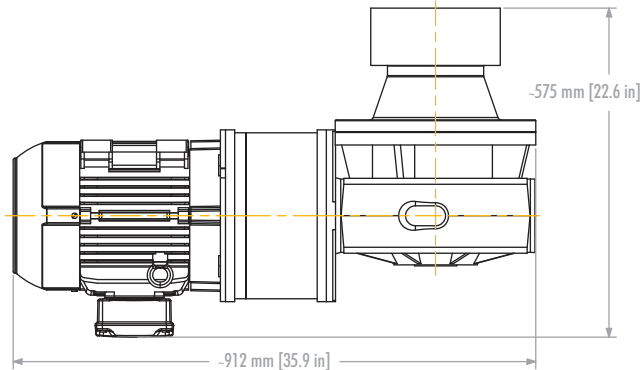

Right Angle Electric Worm Drive

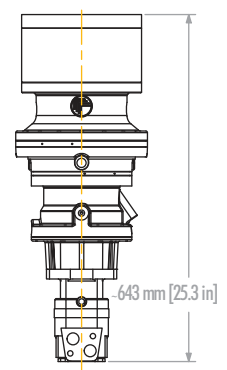

Inline Hydraulic Planetary Drive
*option available for extra cost

VR/VRC 11000

Vertical Windlass

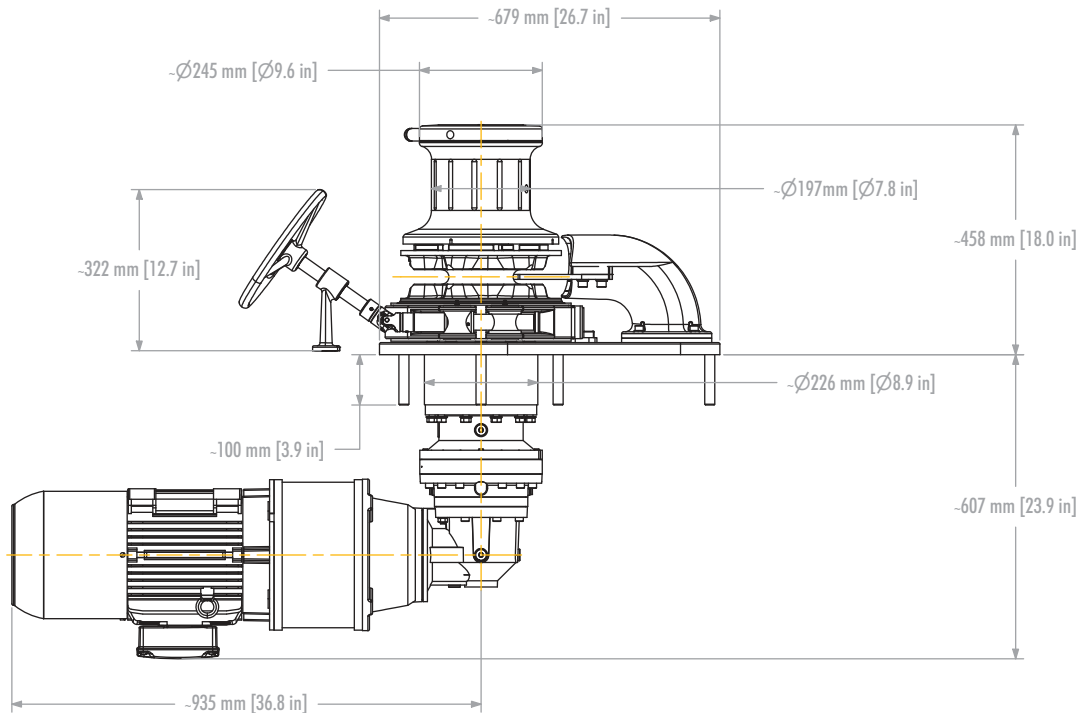

PERFORMANCE CRITERIA

MODEL	VRC11000	VRC11000	VRC11000
Maximum Pull (kg/lb)	5000 / 11000	5000 / 11000	5000 / 11000
Continuous Pull (kg/lb)	2600 / 5720	2600 / 5720	3850 / 8470
Recommended Minimum Speed (m/pmin - f/pmin)	10 / 33	10 / 33	10 / 33
Maximum Recovery High Speed (m/pmin - f/pmin)	20 / 66	20 / 66	20 / 66
Power Supply	3PH / 50HZ	3PH / 60HZ	HYDRAULIC
Input Power (kW)	7.5	7.5	
Hydraulic Flow (l/pmin-USgpm)			30 / 7.9
Maximum Flow (l/pmin-USgpm)			60 / 15.8
Pressure (bar/PSI)			175 / 2537
Maximum Pressure (bar/PSI)			200 / 2900
Chain Size			
Short link up to	22mm	22mm	22mm
Stud link up to	22mm U2/19mm U3	22mm U2/19mm U3	22mm U2/19mm U3
Brake Size	356 / 14	356 / 14	356 / 14
Average Weight (kg/lb)	403 / 886	403 / 886	315 / 693

High Pressure 240 BAR
3600PSI optional

VR/VRC 11000

Vertical Windlass

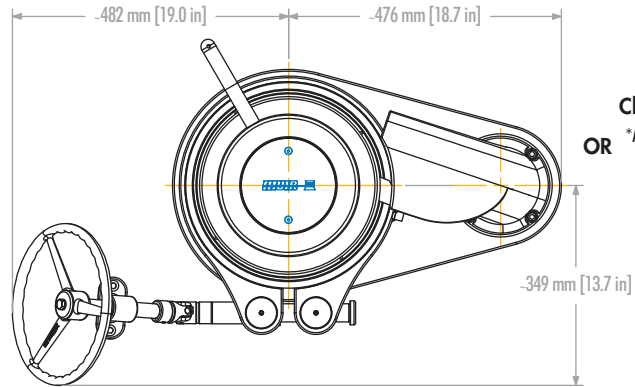
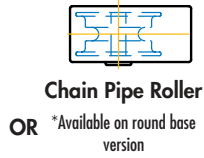
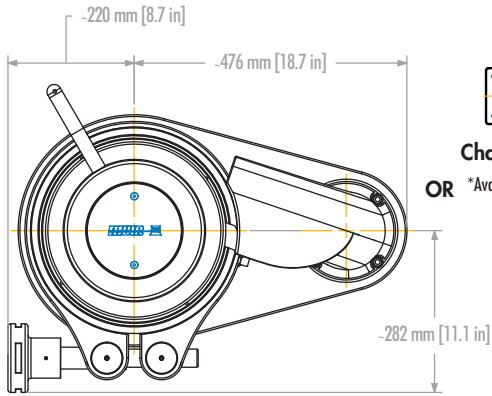

Integral Base Standard Brake with Chain Pipe
*Roundbase option available for extra cost

Integral Base 35° Brake with Handwheel and Chain Pipe
*Roundbase option available for extra cost

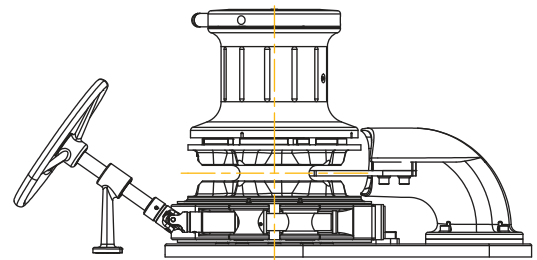
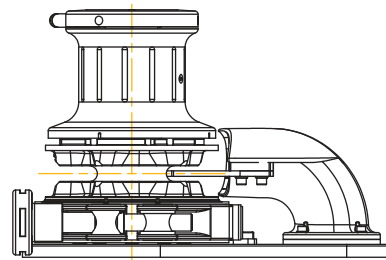
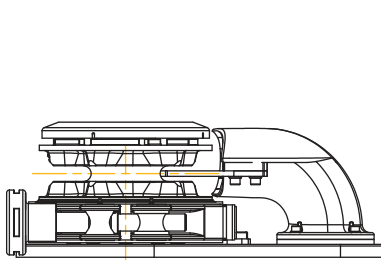

VR Low Profile Integral Base Standard Brake

VRC Integral Base Standard Brake

VRC Integral Base 35° Brake/Handwheel

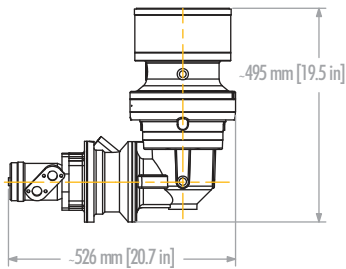

Right Angle Hydraulic Planetary Drive

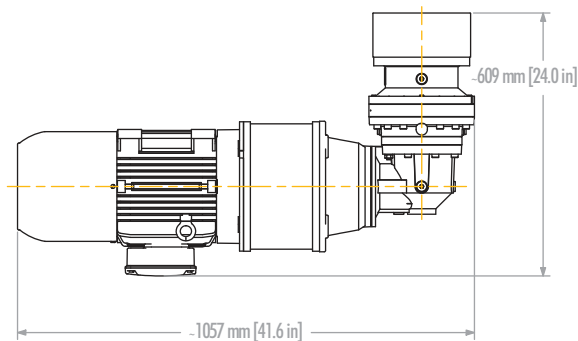

Right Angle Electric Planetary Drive

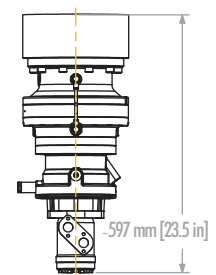

Inline Hydraulic Planetary Drive

VR/VRC 13000

Vertical Windlass

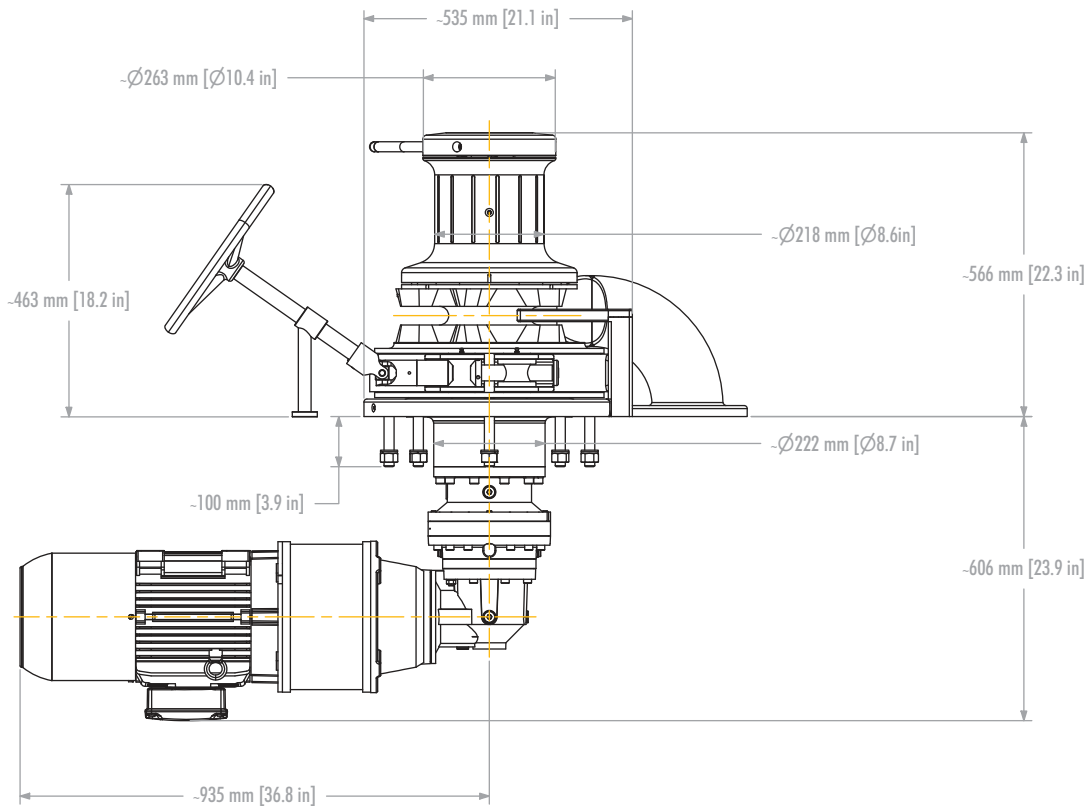

PERFORMANCE CRITERIA

MODEL	VRC13000	VRC13000	VRC13000
Maximum Pull (kg/lb)	5909 / 13000	5909 / 13000	5909 / 13000
Continuous Pull (kg/lb)	3300 / 6966	3300 / 6966	3900 / 8580
Recommended Minimum Speed (m/pmin - f/pmin)	10 / 33	10 / 33	10 / 33
Maximum Recovery High Speed (m/pmin - f/pmin)	20 / 66	20 / 66	20 / 66
Power Supply	3PH / 50HZ	3PH / 60HZ	HYDRAULIC
Input Power (kW)	9.2	9.2	
Hydraulic Flow (l/pmin-USgpm)			32 / 8.5
Maximum Flow (l/pmin-USgpm)			64 / 17
Pressure (bar/PSI)			175 / 2537
Maximum Pressure (bar/PSI)			200 / 2900
Chain Size			
Short link up to	22mm	22mm	22mm
Stud link up to	24mm U2/22mm U3	24mm U2/22mm U3	24mm U2/22mm U3
Brake Size	457 / 18	457 / 18	457 / 18
Average Weight (kg/lb)	520 / 1144	520 / 1144	400 / 880

High Pressure 240 BAR
3600PSI optional

VR/VRC 13000

Vertical Windlass

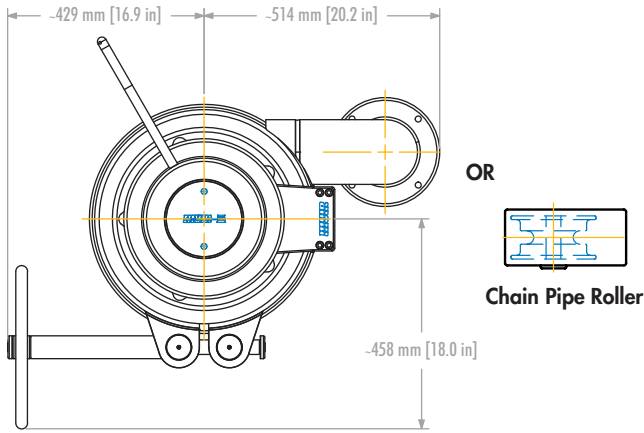

Round Base Standard Brake
(with Curved Chain Pipe or optional Chain Pipe Roller)

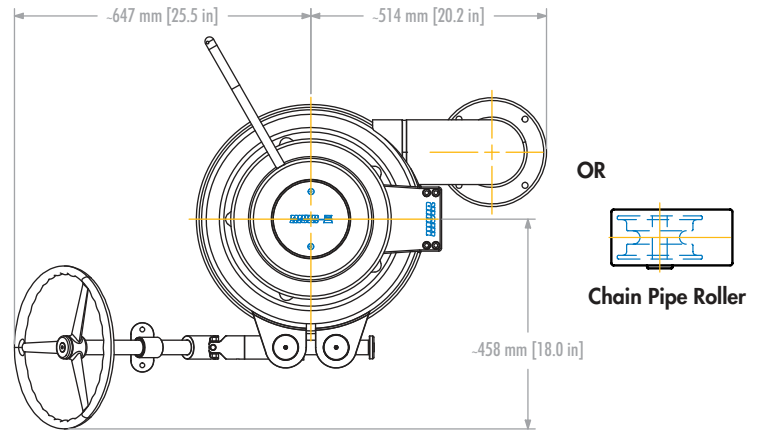

Round Base with 35° Brake and Handwheel
(with Curved Chain Pipe or optional Chain Pipe Roller)

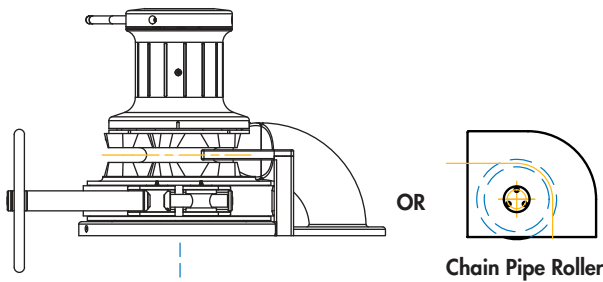

Round Base with Standard Brake

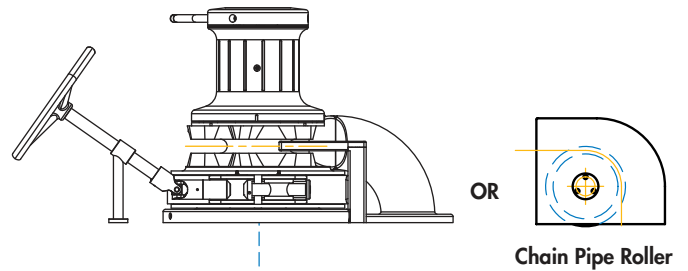

Round Base with 35° Brake and Handwheel

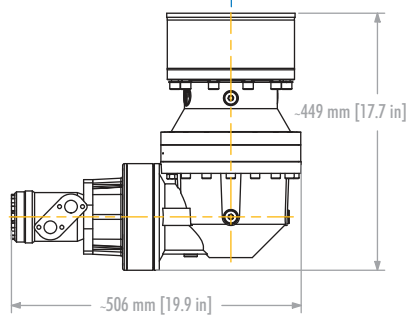

Right Angle Hydraulic Planetary Drive

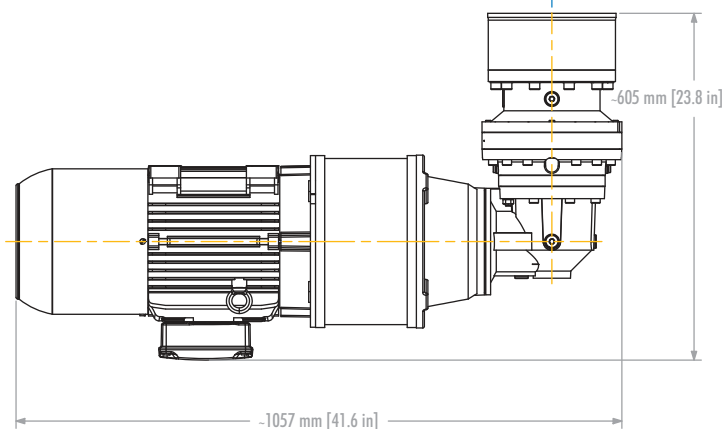

Right Angle Electric Planetary Drive

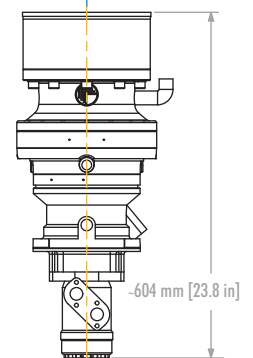

Inline Hydraulic Planetary Drive

VR/VRC 15000

Vertical Windlass

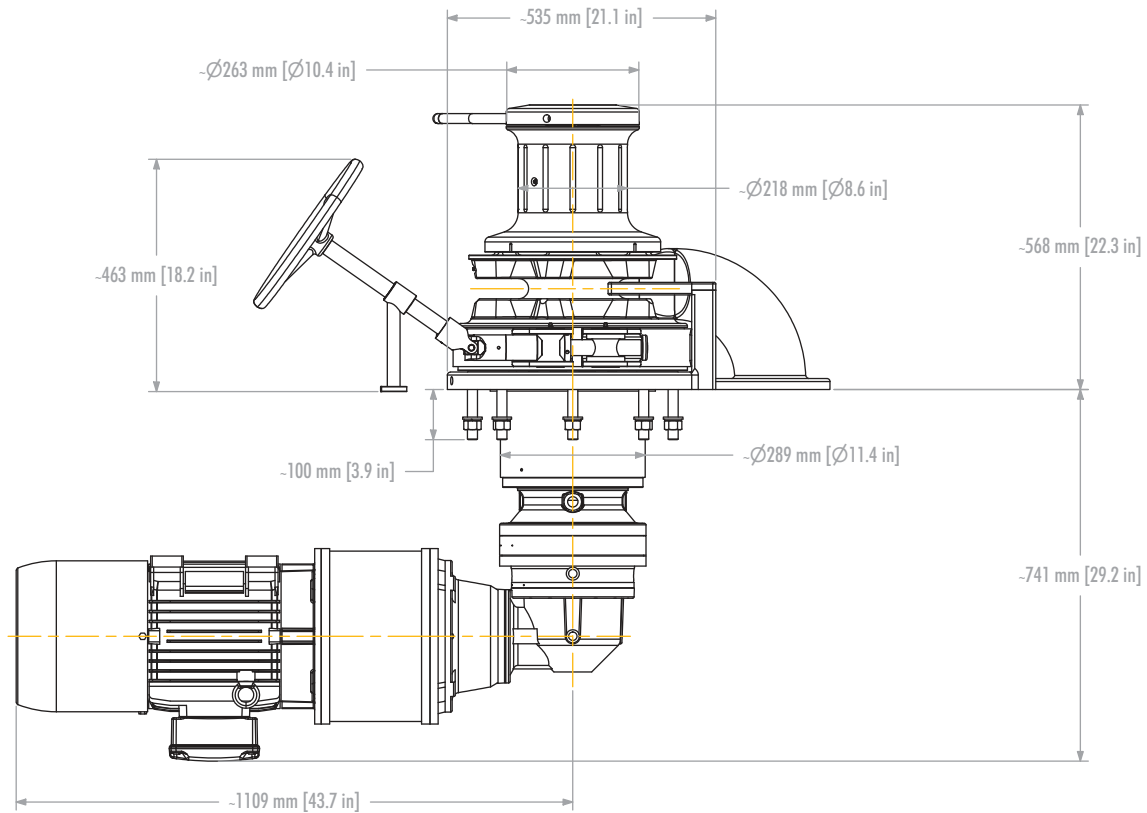

PERFORMANCE CRITERIA

MODEL	VRC15000	VRC15000	VRC15000
Maximum Pull (kg/lb)	6818 / 15000	6818 / 15000	6818 / 15000
Continuous Pull (kg/lb)	3600 / 7920	3600 / 7920	4300 / 9460
Recommended Minimum Speed (m/pmin - f/pmin)	10 / 33	10 / 33	10 / 33
Maximum Recovery High Speed (m/pmin - f/pmin)	20 / 66	20 / 66	20 / 66
Power Supply	3PH / 50HZ	3PH/60HZ	HYDRAULIC
Input Power (kW)	9.2/11	9.2/ 11	
Hydraulic Flow (l/pmin-USgpm)			34 / 9
Maximum Flow (l/pmin-USgpm)			68 / 18
Pressure (bar/PSI)			175 / 2537
Maximum Pressure (bar/PSI)			200 / 2900
Chain Size			
Stud link up to	26mm U2 / 24mm U3	26mm U2 / 24mm U3	26mm U2 / 24mm U3
Brake Size	457 / 18	457 / 18	457 / 18
Average Weight (kg/lb)	640 / 1408	640 / 1408	520 / 1144

High Pressure 240 BAR
3600PSI optional

VR/VRC 15000

Vertical Windlass

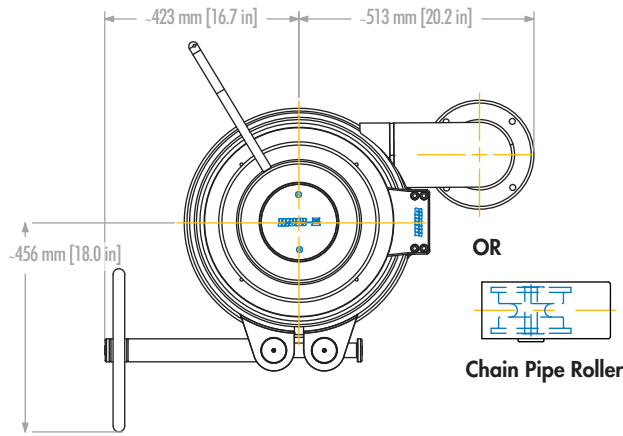

Round Base Standard Brake
(with Curved Chain Pipe or optional Chain Pipe Roller)

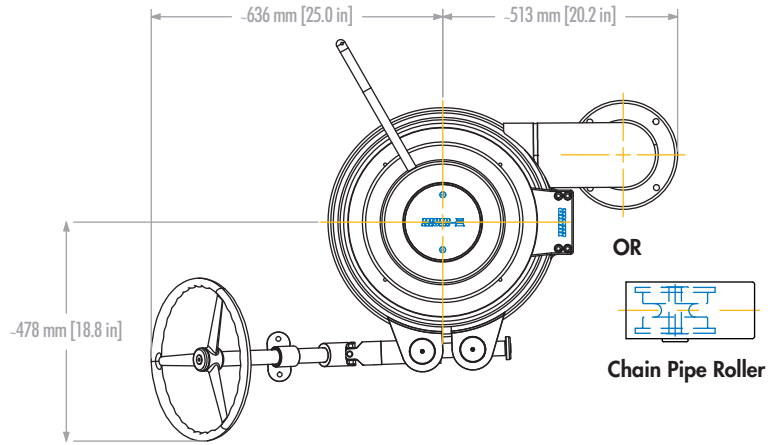

Round Base 35° with Brake and Handwheel
(with Curved Chain Pipe or optional Chain Pipe Roller)

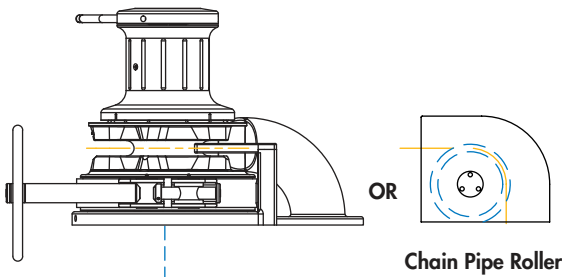

Round Base with Standard Brake

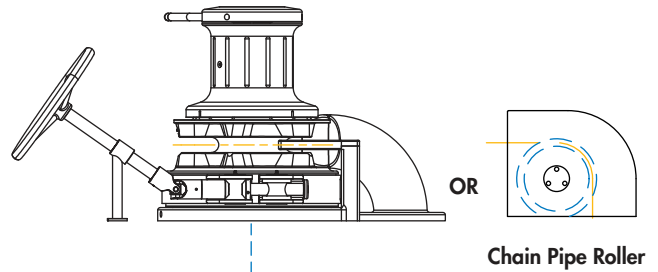

Round Base with 35° Brake and Handwheel

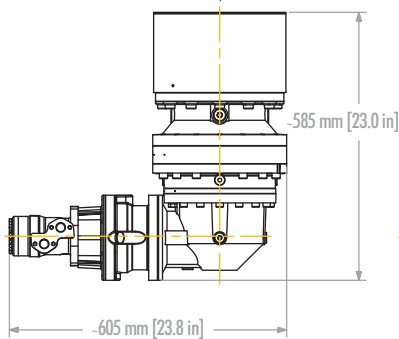

Right Angle Hydraulic Planetary Drive

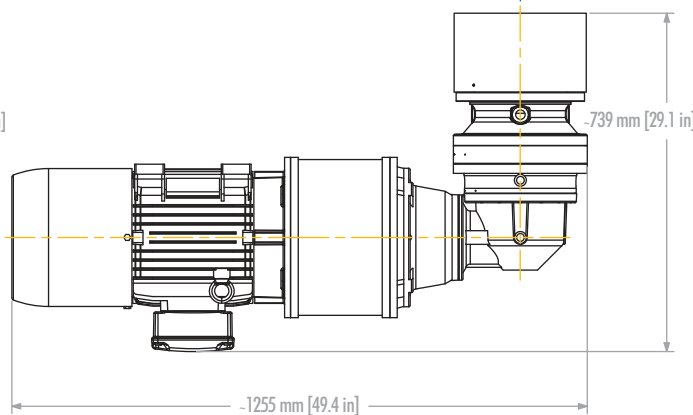

Right Angle Electric Planetary Drive

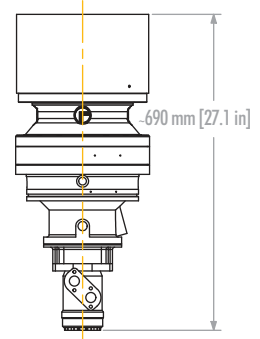

Inline Hydraulic Planetary Drive

VR/VRC 18000

Vertical Windlass

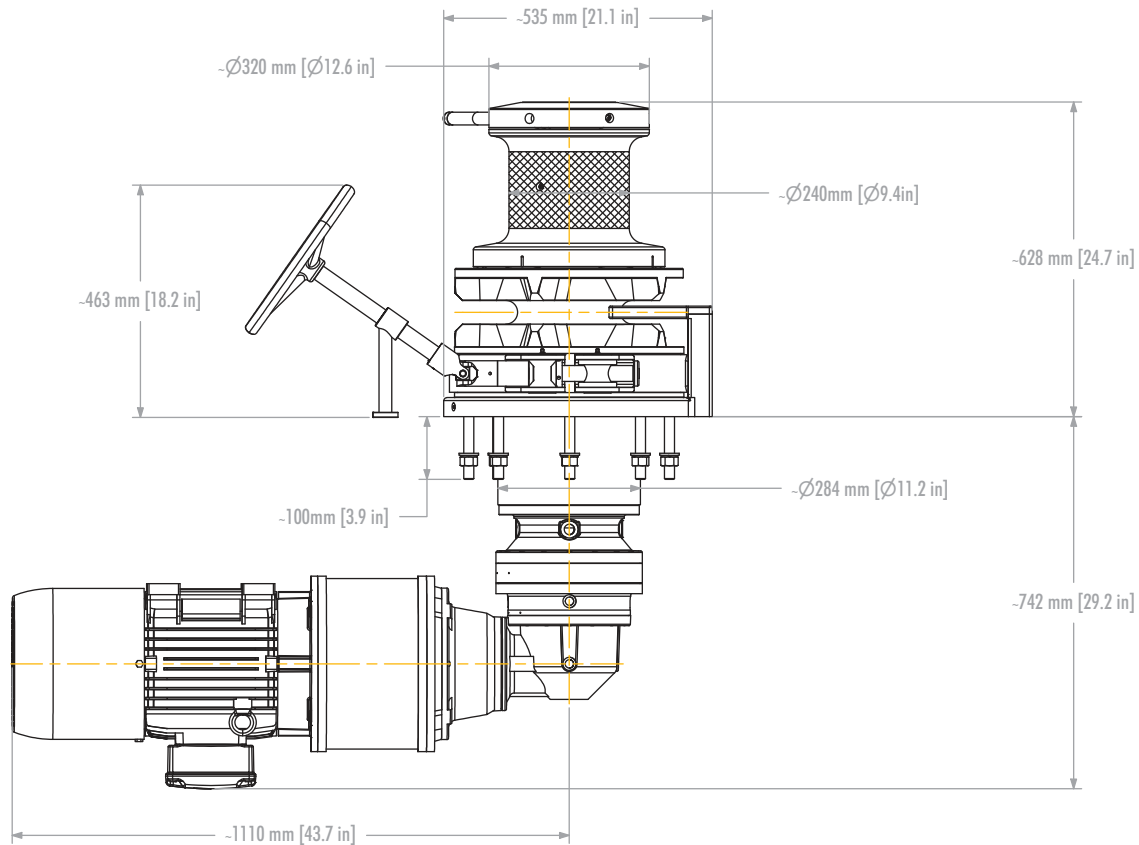

PERFORMANCE CRITERIA

MODEL	VRC18000	VRC18000	VRC18000
Maximum Pull (kg/lb)	8180 / 18000	8180 / 18000	8180 / 18000
Continuous Pull (kg/lb)	4400 / 9680		4900 / 10780
Recommended Minimum Speed (m/pmin - f/pmin)	10 / 33	10 / 33	10 / 33
Maximum Recovery High Speed (m/pmin - f/pmin)	20 / 66	20 / 66	20 / 66
Power Supply	3PH / 50HZ	3PH / 60HZ	HYDRAULIC
Input Power (kW)	11	11	
Hydraulic Flow (l/pmin-USgpm)			39 / 10.3
Maximum Flow (l/pmin-USgpm)			78 / 20.6
Pressure (bar/PSI)			210 / 3045
Maximum Pressure (bar/PSI)			250 / 3625
Chain Size			
Stud link up to	28mm U2 / 24mm U3	28mm U2 / 24mm U3	28mm U2 / 24mm U3
Brake Size	457 / 18	457 / 18	457 / 18
Average Weight (kg/lb)	697 / 1533	697 / 1533	582 / 1280

VR/VRC 18000

Vertical Windlass

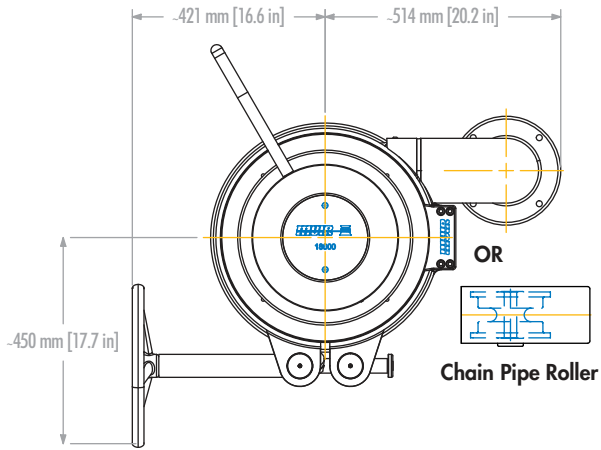

Round Base Standard Brake
(with Curved Chain Pipe or optional Chain Pipe Roller)

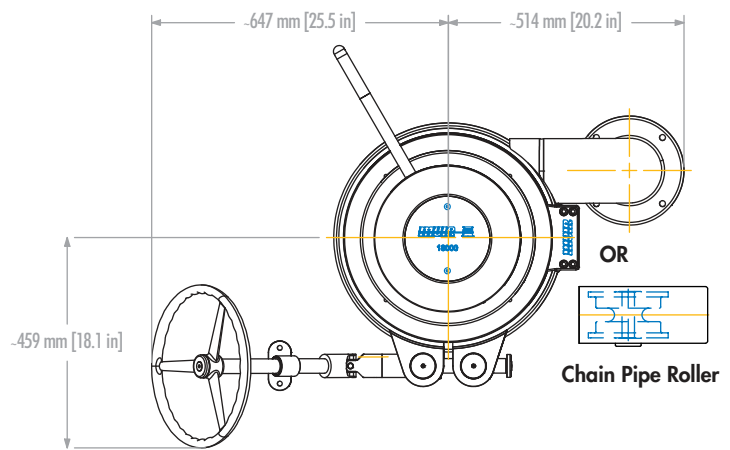

Round Base 35° with Brake and Handwheel
(with Curved Chain Pipe or optional Chain Pipe Roller)

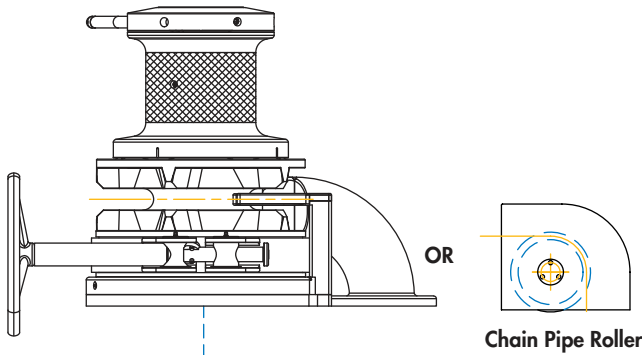

Round Base with Standard Brake

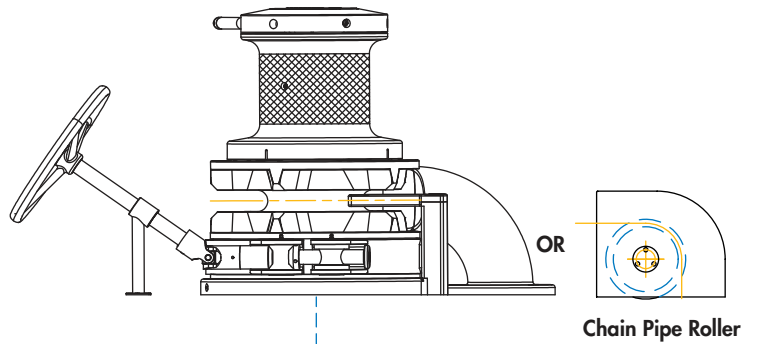

Round Base with 35° Brake and Handwheel

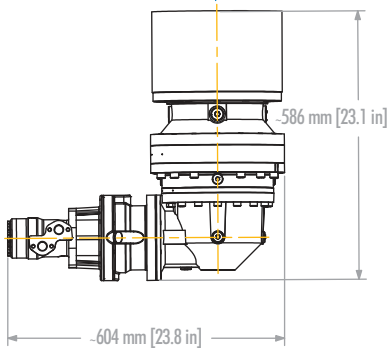

Right Angle Hydraulic Planetary Drive

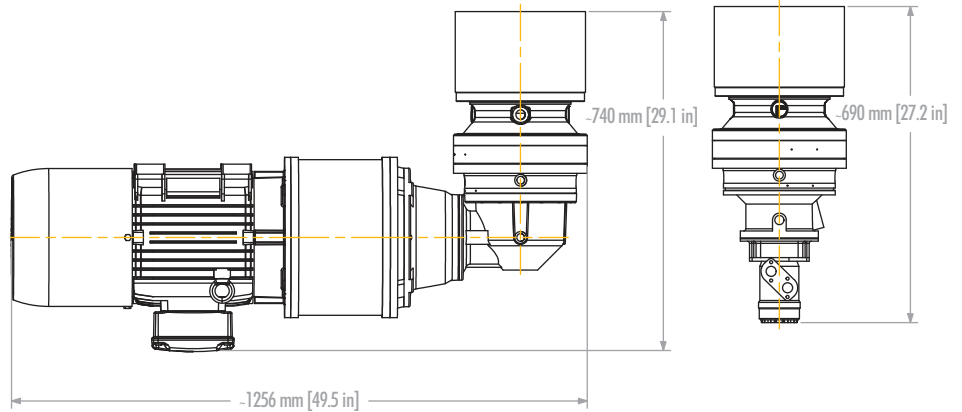

Right Angle Electric Planetary Drive

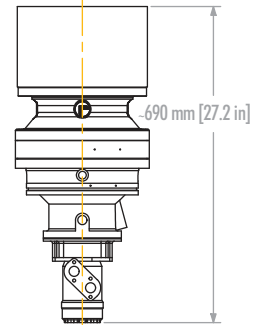

Inline Hydraulic Planetary Drive

VR/VRC 20000

Vertical Windlass

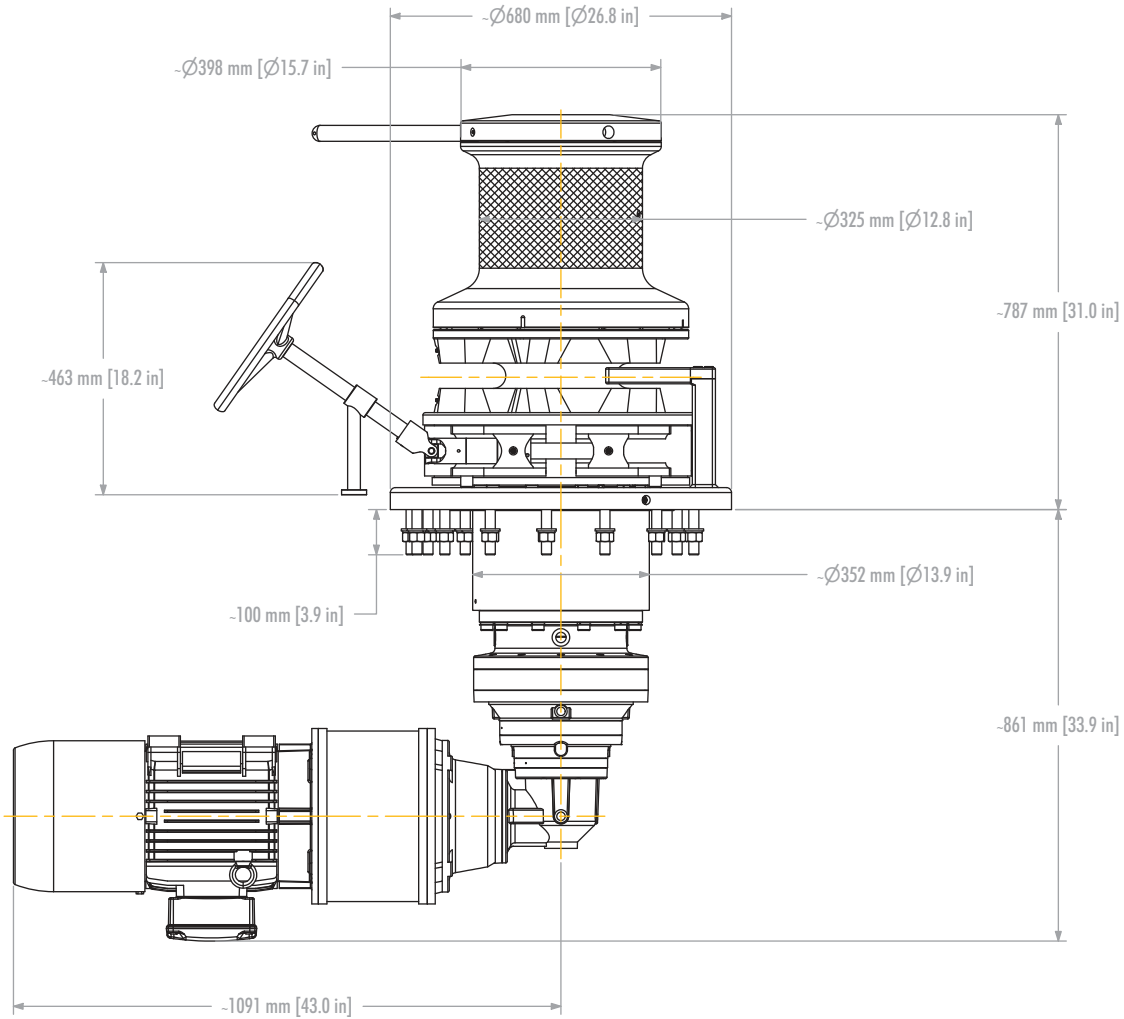

PERFORMANCE CRITERIA

MODEL	VRC20000	VRC20000	VRC20000
Maximum Pull (kg/lb)	9090 / 20000	9090 / 20000	9090 / 20000
Continuous Pull (kg/lb)	6000 / 13200	6000 / 13200	7200 / 15840
Recommended Minimum Speed (m/pmin - f/pmin)	10 / 33	10 / 33	10 / 33
Maximum Recovery High Speed (m/pmin - f/pmin)	20 / 66	20 / 66	20 / 66
Power Supply	3PH / 50HZ	3PH / 60HZ	HYDRAULIC
Input Power (kW)	11 / 15	11 / 15	
Hydraulic Flow (l/pmin-USgpm)			50 / 13
Maximum Flow (l/pmin-USgpm)			98 / 25
Pressure (bar/PSI)			210 / 3045
Maximum Pressure (bar/PSI)			250 / 3635
Chain Size			
Stud link up to	32mm U2 / 30mm U3 /	32mm U2 / 30mm U3	32mm U2 / 30mm U3
Brake Size	520 / 24	520 / 24	520 / 24
Average Weight (kg/lb)	1200	1200	1015

VR/VRC 20000

Vertical Windlass

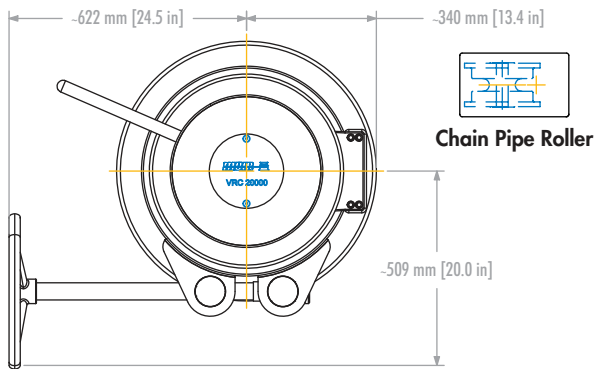

Round Base Standard Brake
with Chain Pipe Roller

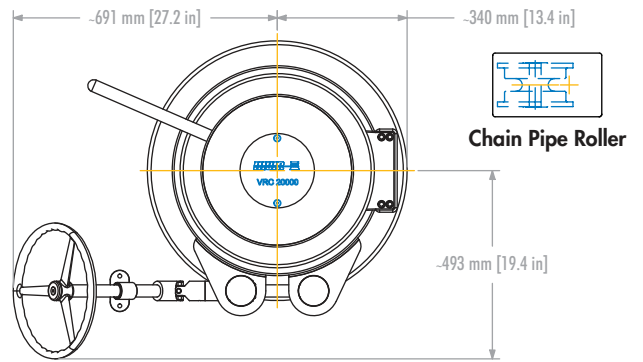

Round Base with 35° Brake and Handwheel
with Chain Pipe Roller

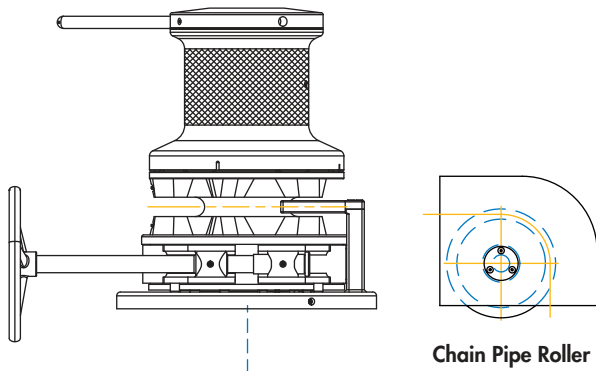

Round Base with Standard Brake

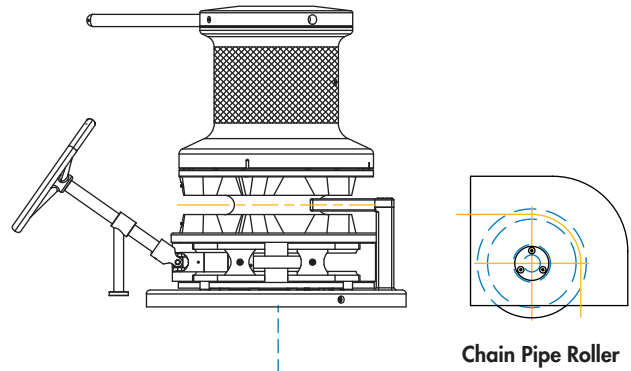

Round Base with 35° Brake and Handwheel

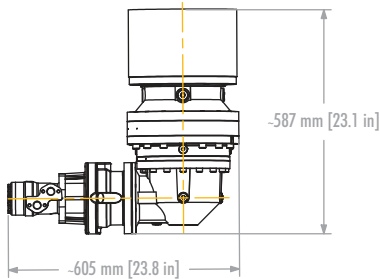

Right Angle Hydraulic Planetary Drive

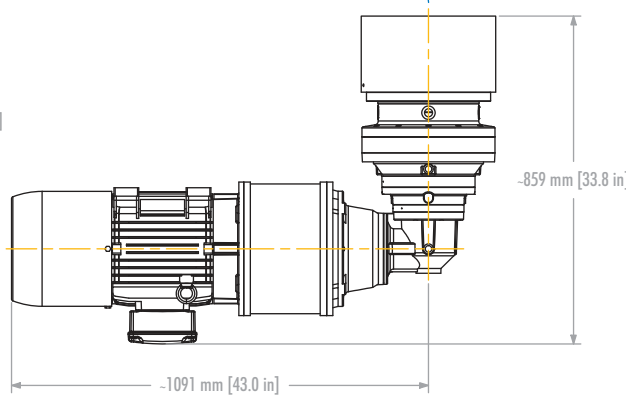

Right Angle Electric Planetary Drive

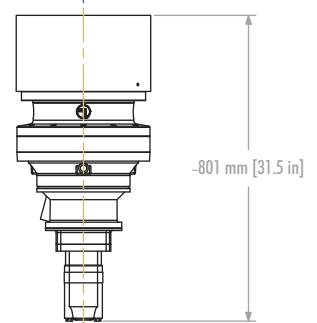

Inline Hydraulic Planetary Drive

VR/VRC 22000/23000 Vertical Windlass

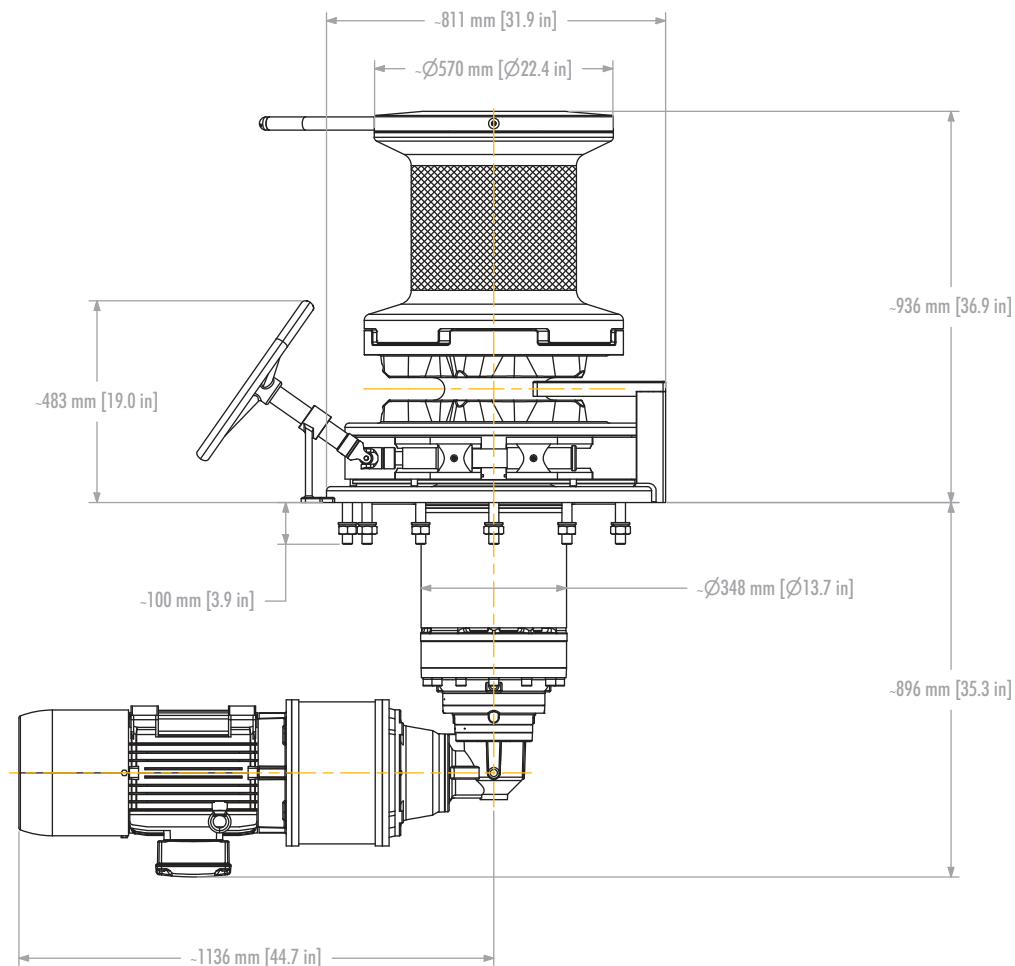

PERFORMANCE CRITERIA

MODEL	VRC22000/23000	VRC22000/23000	VRC22000/23000
Maximum Pull (kg/lb)	11000 / 24200	11000 / 24200	11000 / 24200
Continuous Pull (kg/lb)	7000 / 15400	7000 / 15400	7500 / 15500
Recommended Minimum Speed (m/pmin - f/pmin)	10 / 33	10 / 33	10 / 33
Maximum Recovery High Speed (m/pmin - f/pmin)	20 / 66	20 / 66	20 / 66
Power Supply	3PH / 50HZ	3PH / 60HZ	HYDRAULIC
Input Power (kW)	15 / 18.5	15 / 18.5	
Hydraulic Flow (l/pmin-USgpm)			65 / 17.2
Maximum Flow (l/pmin-USgpm)			120 / 31.7
Pressure (bar/PSI)			210 / 3045
Maximum Pressure (bar/PSI)			250 / 3625
Chain Size			
Stud link up to	38mm U2/ 34mm U3	38mm U2/ 34mm U3	38mm U2/ 34mm U3
Brake Size	610 / 24	610 / 24	610 / 24
Average Weight (kg/lb)	1750 / 3850	1750 / 3850	1700 / 3740

VR/VRC 22000/23000 Vertical Windlass

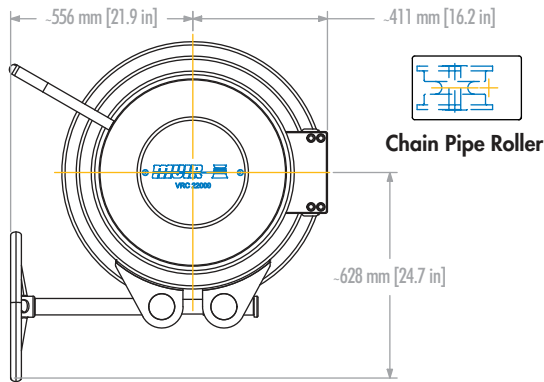

Round Base Standard Brake
with Chain Pipe Roller

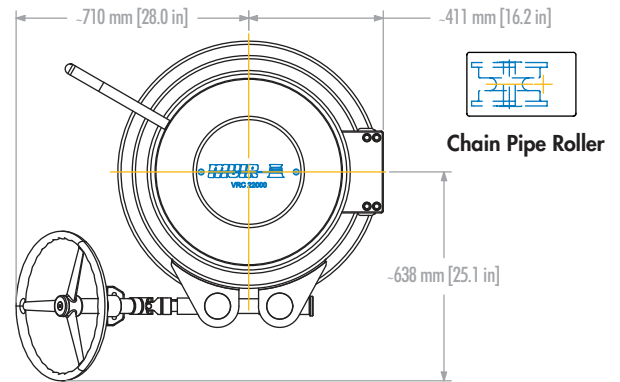

Round Base with 35° Brake and Handwheel
with Chain Pipe Roller

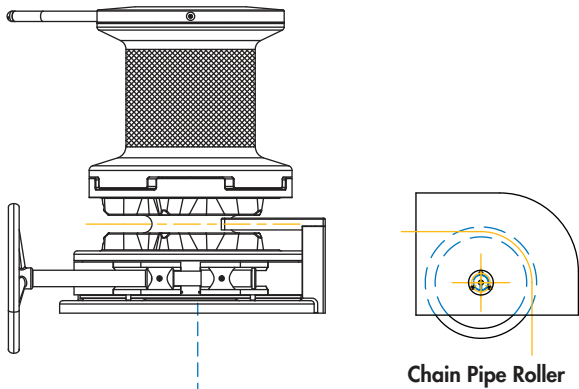

Round Base with Standard Brake

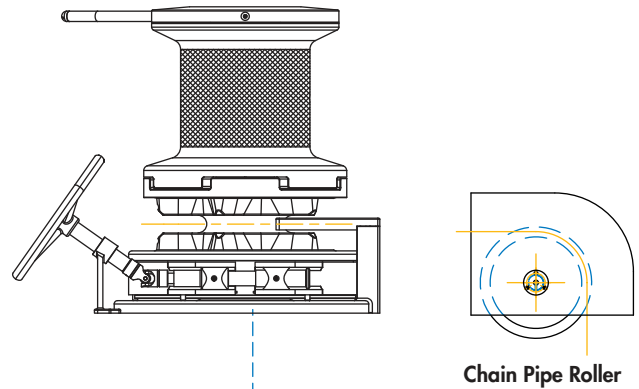

Round Base with 35° Brake and Handwheel

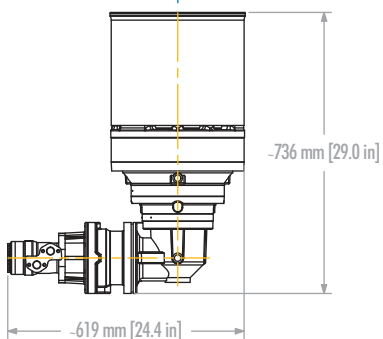

Right Angle Hydraulic Planetary Drive

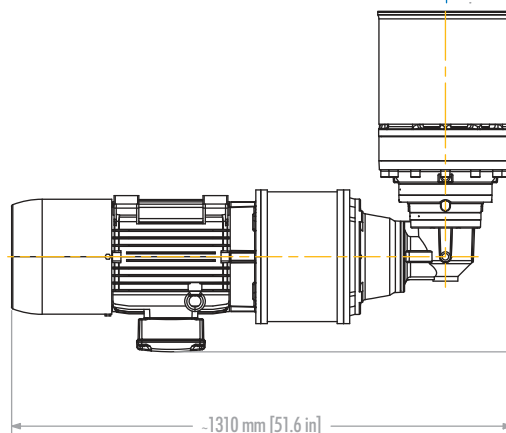

Right Angle Electric Planetary Drive

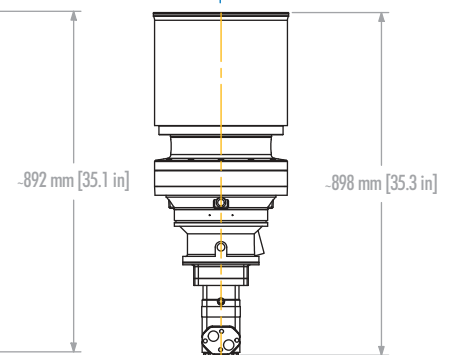

Inline Hydraulic Planetary Drive

VR/VRC 24000/26000 Vertical Windlass

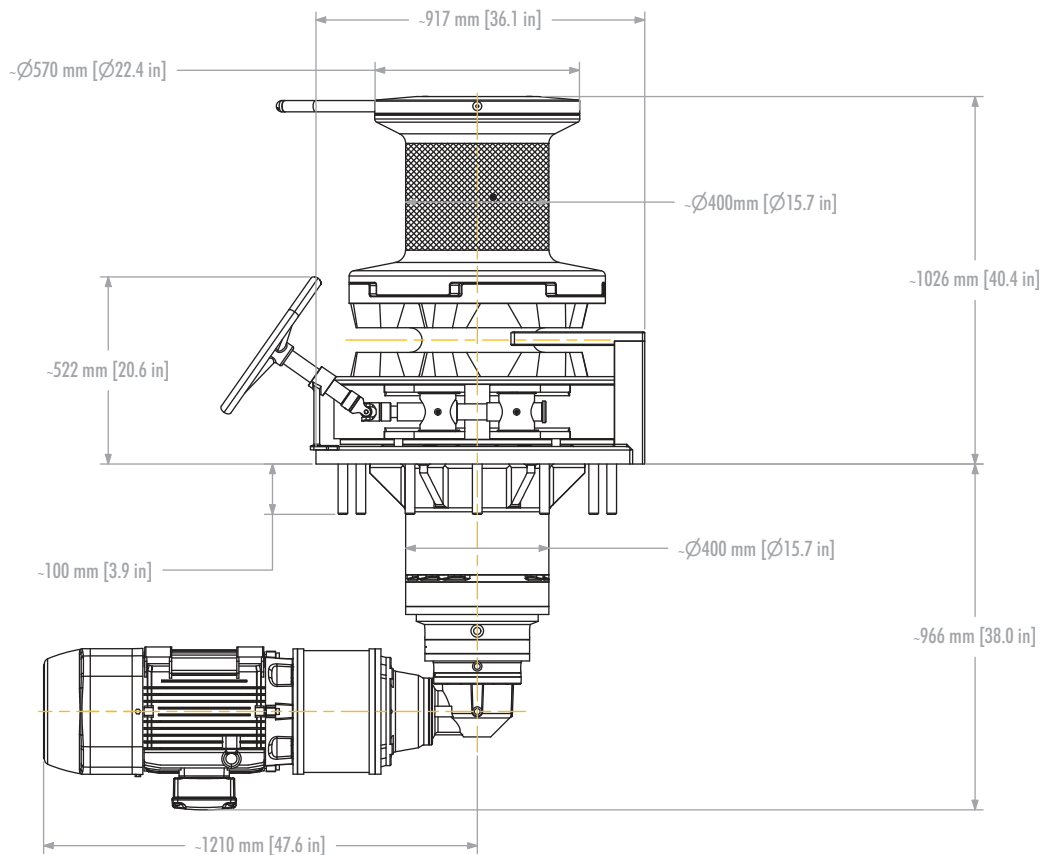

PERFORMANCE CRITERIA

MODEL	VRC24000/26000	VRC24000/26000	VRC24000/26000
Maximum Pull (kg/lb)	13000 / 28600	13000 / 28600	13000 / 28600
Continuous Pull (kg/lb)	8500 / 18700	8500 / 18700	8500 / 18700
Recommended Minimum Speed (m/pmin - f/pmin)	10 / 33	10 / 33	10 / 33
Maximum Recovery High Speed (m/pmin - f/pmin)	20 / 66	20 / 66	20 / 66
Power Supply	3PH / 50HZ	3PH / 60HZ	HYDRAULIC
Input Power (kW)	18.2 / 22	18.2 / 22	
Hydraulic Flow (l/pmin-USgpm)			65 / 17.2
Maximum Flow (l/pmin-USgpm)			120 / 31.7
Pressure (bar/PSI)			210 / 3045
Maximum Pressure (bar/PSI)			250 / 3625
Chain Size			
Stud link up to	46mm U2 / 40mm U3	46mm U2 / 40mm U3	46mm U2 / 40mm U3
Brake Size	725 / 30	725 / 30	725 / 30
Average Weight (kg/lb)	2300 / 5060	2300 / 5060	2150 / 4730

VR/VRC 24000/26000

Vertical Windlass

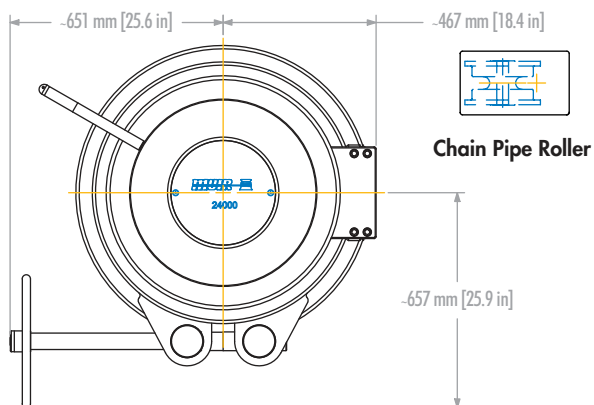

Round Base Standard Brake
with Chain Pipe Roller

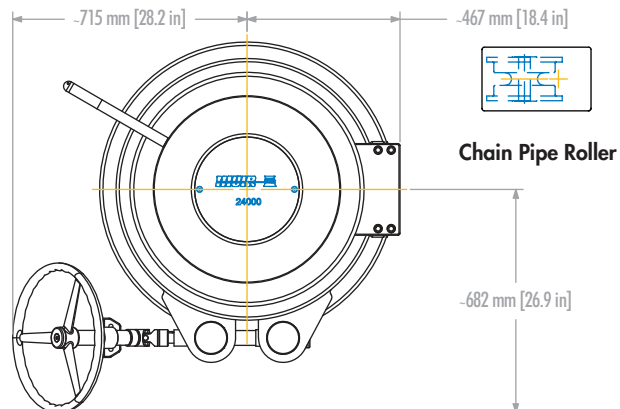

Round Base with 35° Brake and Handwheel
with Chain Pipe Roller

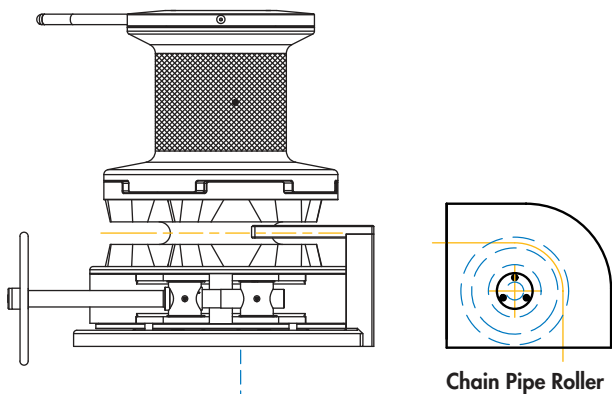

Round Base with Standard Brake

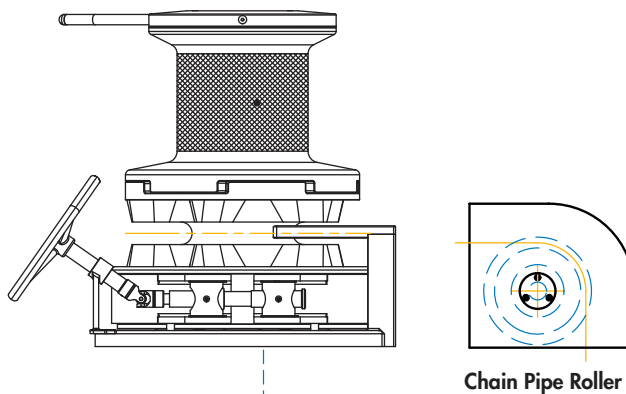

Round Base with 35° Brake and Handwheel

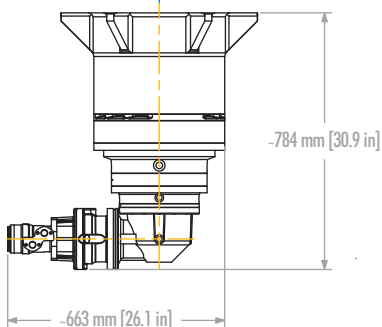

Right Angle Hydraulic Planetary Drive

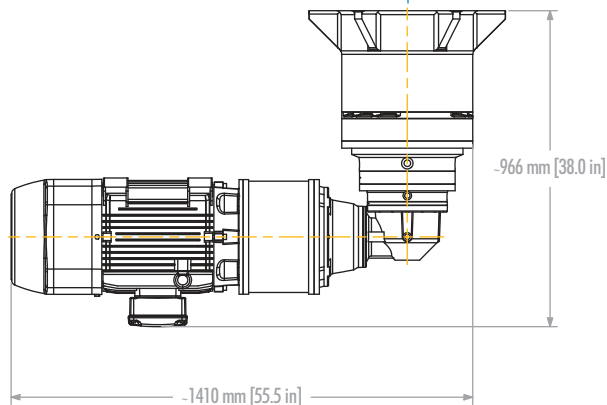

Right Angle Electric Planetary Drive

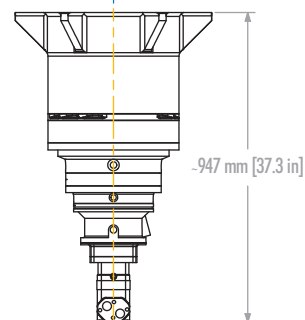

Inline Hydraulic Planetary Drive

HR5000

Horizontal Windlass

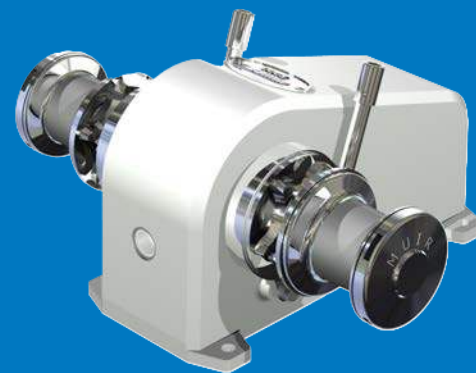

*Gypsy centre varies with chain size

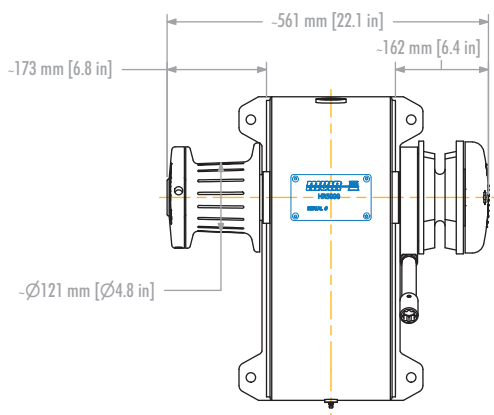

Single Capstan Single Gypsy

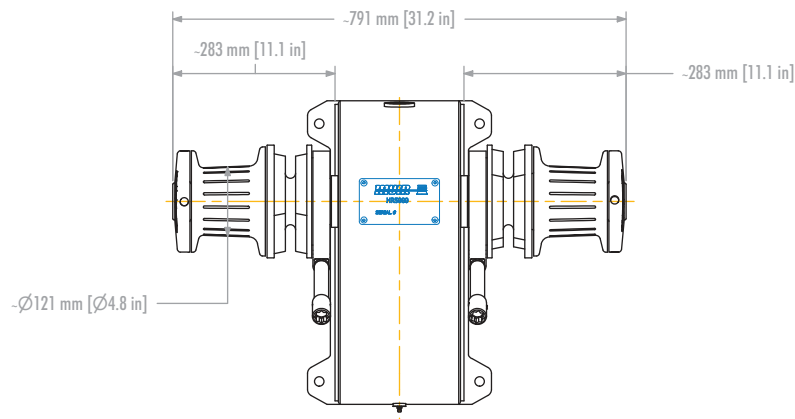

Twin Gypsy Twin Capstan

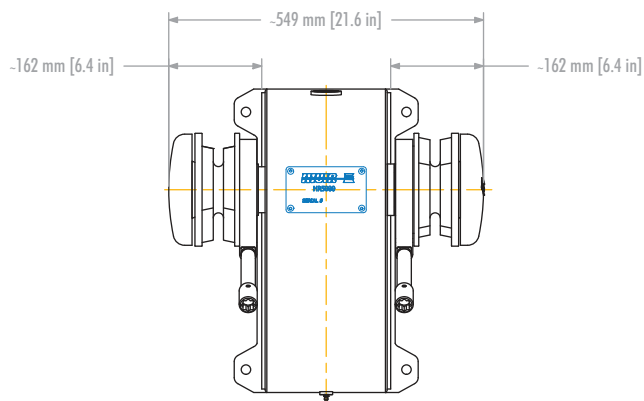
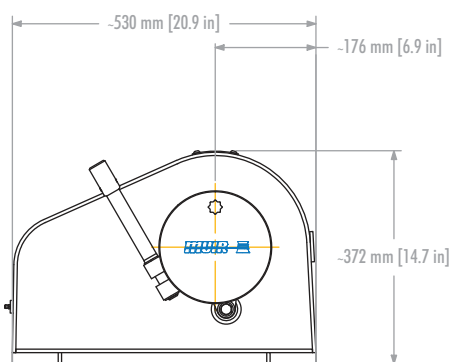

Twin Gypsy

PERFORMANCE CRITERIA

MODEL	HR5000	HR5000
Maximum Pull (kg/lb)	2500 / 5500	2500 / 5500
Continuous Pull (kg/lb)	1950 / 2090	1600 / 3520
Recommended Minimum Speed (m/pmin - f/pmin)	15 / 50	10 / 33
Maximum Recovery High Speed (m/pmin - f/pmin)		20 / 66
Power Supply	24VDC	HYDRAULIC
Input Power (kW)	3 / 3.5	
Hydraulic Flow (l/pmin-USgpm)		26 / 6.9
Maximum Flow (l/pmin-USgpm)		52 / 13.7
Pressure (bar/PSI)		175 / 2537
Maximum Pressure (bar/PSI)		200 / 2900
Chain Size		
Short link up to	16mm	16mm
Stud link up to	14mm U2	14mm U2
Brake Size	150/230mm	150/230mm
Average Weight (kg/lb)	130 / 286	113 / 248

HR6000

Horizontal Windlass



*Gypsy centre varies with chain size

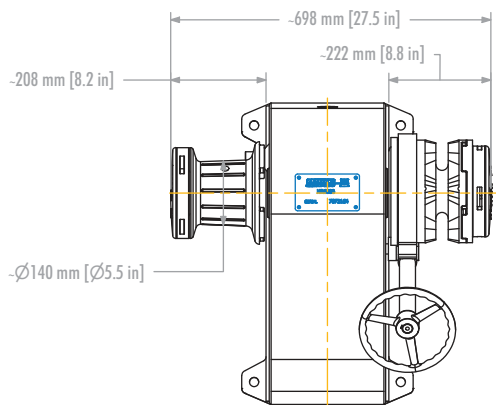

Single Capstan Single Gypsy

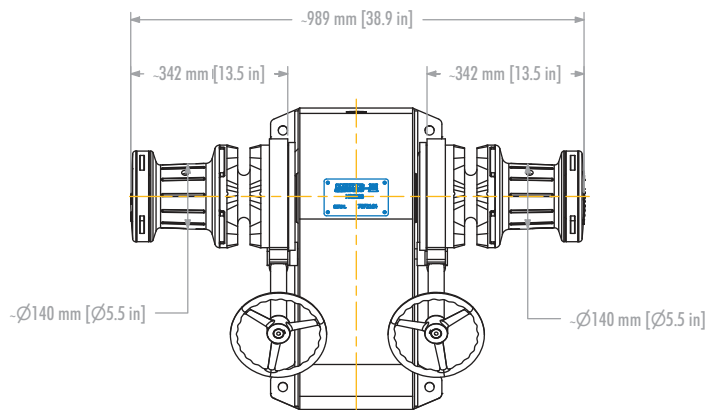

Twin Gypsy Twin Capstan

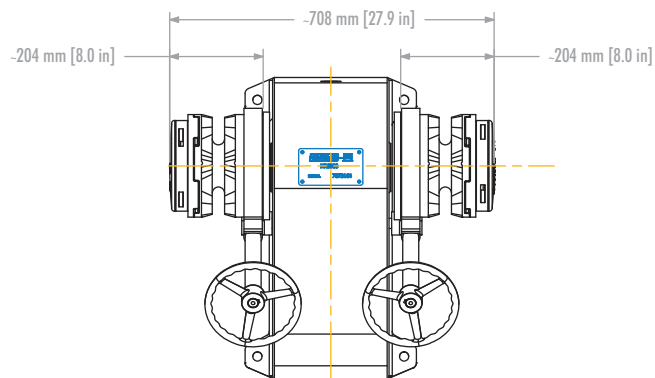
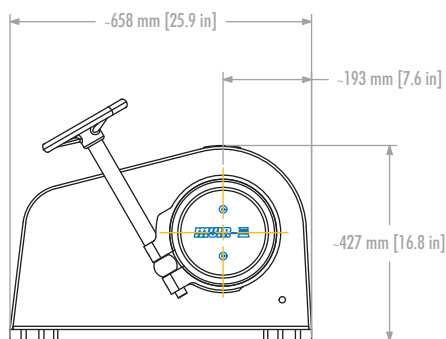

Twin Gypsy

PERFORMANCE CRITERIA

MODEL	H6000	H6000
Maximum Pull (kg/lb)	2900 / 6380	2900 / 6380
Continuous Pull (kg/lb)	1409 / 3100	2138 / 4703
Recommended Minimum Speed (m/pmin - f/pmin)	15 / 50	10 / 33
Maximum Recovery High Speed (m/pmin - f/pmin)		20 / 66
Power Supply	24VDC	HYDRAULIC
Input Power (kW)	3 / 3.5	
Hydraulic Flow (l/pmin-USgpm)		28 / 7.4
Maximum Flow (l/pmin-USgpm)		56 / 14.8
Pressure (bar/PSI)		175 / 2537
Maximum Pressure (bar/PSI)		200 / 2900
Chain Size		
Short link up to	16mm / 5 / 8"	16mm / 5 / 8"
Stud link up to	16mm U2 / 14mm U3	16mm U2 / 14mm U3
Brake Size	230 / 9	230 / 9
Average Weight (kg/lb)	370 / 814	335 / 781

HR8000

Horizontal Windlass



*Gypsy centre varies with chain size

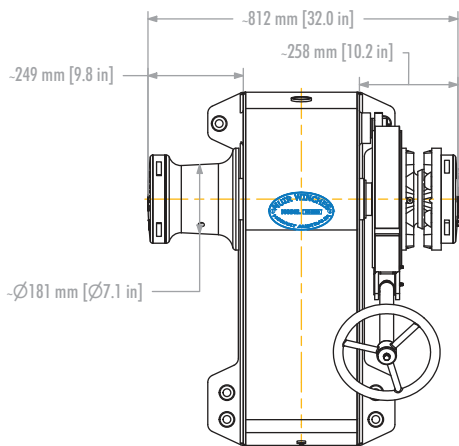

Single Capstan Single Gypsy

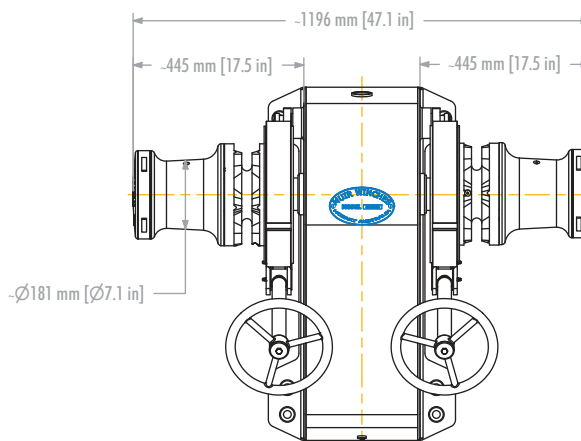

Twin Gypsy Twin Capstan

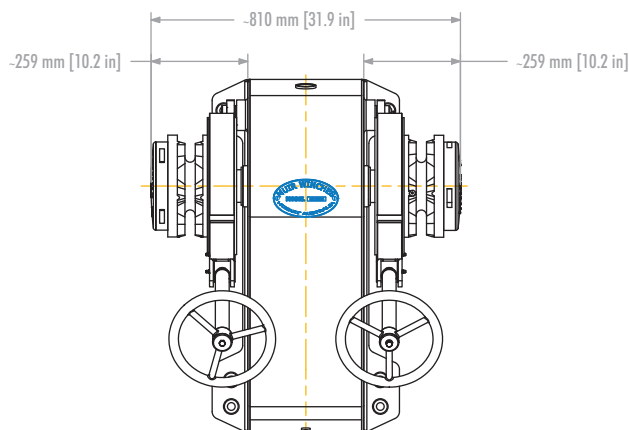
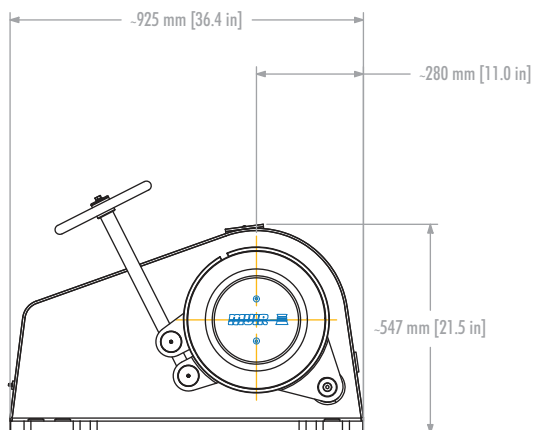

Twin Gypsy

PERFORMANCE CRITERIA

MODEL	HR8000	HR8000	HR8000
Maximum Pull (kg/lb)	3636 / 8000	3636 / 8000	2636 / 8000
Continuous Pull (kg/lb)	2400 / 5280	2400 / 5280	2900 / 6380
Recommended Minimum Speed (m/pmin - f/pmin)	10 / 33	10 / 33	10 / 33
Maximum Recovery High Speed (m/pmin - f/pmin)	20 / 66	20 / 66	20 / 66
Power Supply	3PH / 50HZ	3PH / 50HZ	HYDRAULIC
Input Power (kW)	5.5	5.5	
Hydraulic Flow (l/pmin-USgpm)			28 / 7.4
Maximum Flow (l/pmin-USgpm)			56 / 14.8
Pressure (bar/PSI)			170 / 2537
Maximum Pressure (bar/PSI)			200 / 2900
Chain Size			
Short link up to	19mm	19mm	22mm
Stud link up to	19mm U2/17.5mm U3	19mm U2/17.5mm U3	19mm U2/17.5mm U3
Brake Size	356/14	356/14	356/14
Average Weight (kg/lb)	502 / 1140	502 / 1140	450/990

HR11000

Horizontal Windlass



*Gypsy centre varies with chain size

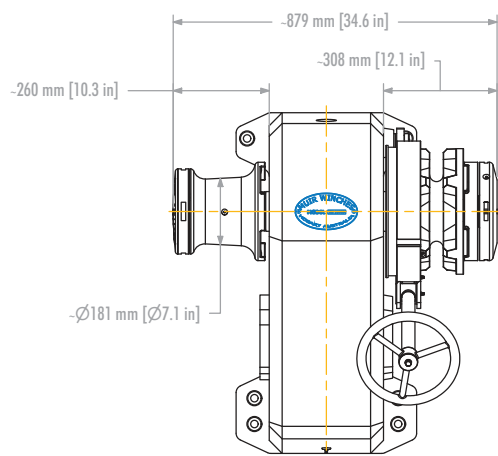

Single Capstan Single Gypsy

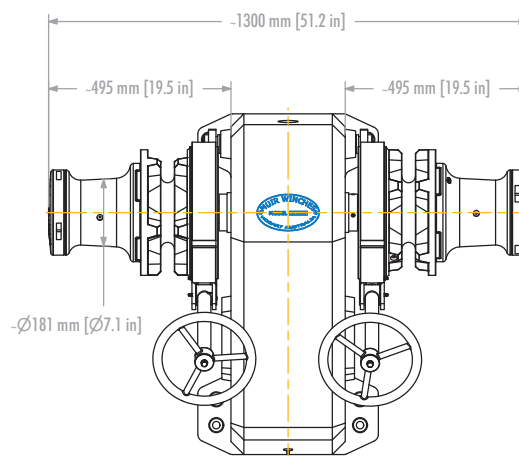

Twin Gypsy Twin Capstan

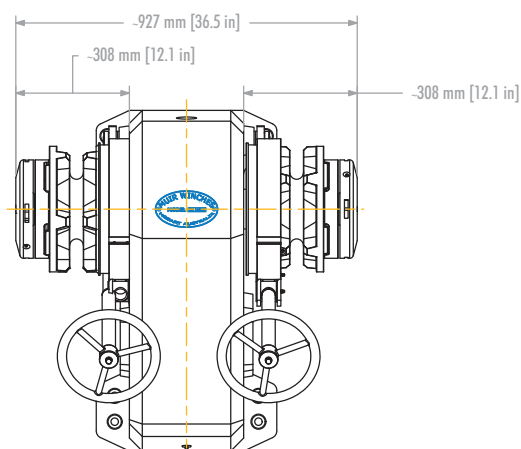
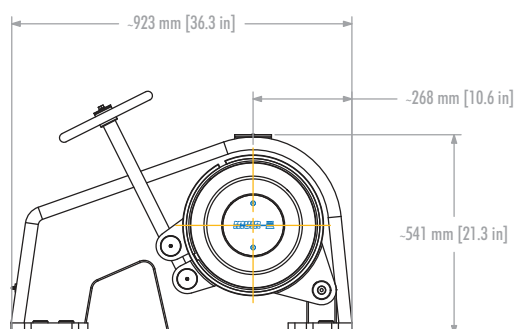

Twin Gypsy

PERFORMANCE CRITERIA

MODEL	HR11000	HR11000	HR11000
Maximum Pull (kg/lb)	5000 / 11000	5000 / 11000	5000 / 11000
Continuous Pull (kg/lb)	2600 / 5720	2600 / 5720	3200 / 7040
Recommended Minimum Speed (m/pmin - f/pmin)	10 / 33	10 / 33	10 / 33
Maximum Recovery High Speed (m/pmin - f/pmin)	20 / 66	20 / 66	20 / 66
Power Supply	3PH / 50HZ	3PH / 50HZ	HYDRAULIC
Input Power (kW)	7.5	7.5	
Hydraulic Flow (l/pmin-USgpm)			30 / 7.9
Maximum Flow (l/pmin-USgpm)			60 / 15.8
Pressure (bar/PSI)			170/2537
Maximum Pressure (bar/PSI)			200/2900
Chain Size			
Short link up to	22mm	22mm	22mm
Stud link up to	20.5mm U2/19mm U3	20.5mm U2/19mm	20.5mm U2/19mm
Brake Size	356 / 14	356 / 14	356/14
Average Weight (kg/lb)	536 / 1179	536 / 1179	450/990

High Pressure 240 BAR
3600PSI optional

HR15000

Horizontal Windlass



*Gypsy centre varies with chain size

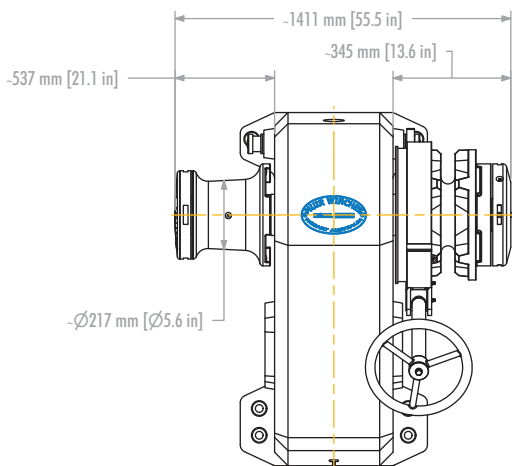

Single Capstan Single Gypsy

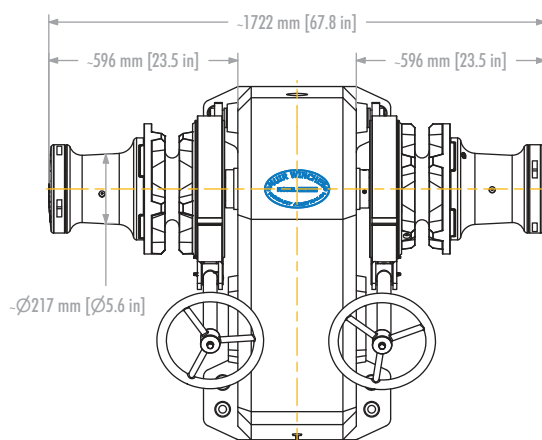

Twin Gypsy Twin Capstan

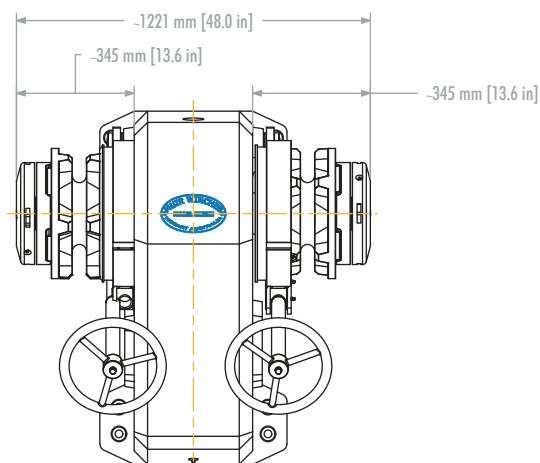
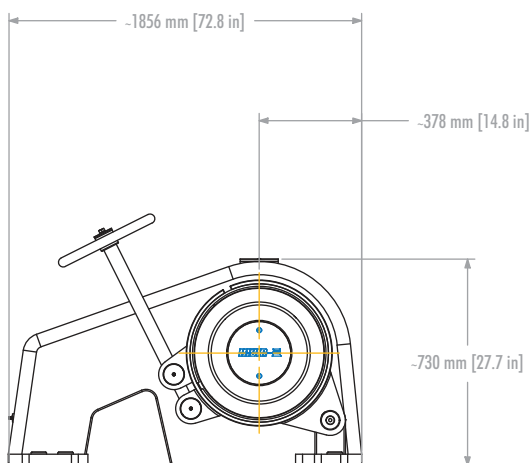

Twin Gypsy

PERFORMANCE CRITERIA

MODEL	HR15000	HR15000	HR15000
Maximum Pull (kg/lb)	6820 / 15000	6820 / 15000	6820/15000
Continuous Pull (kg/lb)	3500 / 7700	3500 / 7700	4600 / 10120
Recommended Minimum Speed (m/pmin - f/pmin)	13/43	13/43	10/33
Maximum Recovery High Speed (m/pmin - f/pmin)			20/66
Power Supply	3PH/50HZ	3PH/60HZ	HYDRAULIC
Input Power (kW)	11	11	
Hydraulic Flow (l/pmin-USgpm)			34 / 9
Maximum Flow (l/pmin-USgpm)			68 / 18
Pressure (bar/PSI)			175/2537
Maximum Pressure (bar/PSI)			200/2900
Chain Size			
Short link up to			
Stud link up to	26mm U2/24mm U3	26mm U2/24mm U3	26mm U2/24mm U3
Brake Size	457/18	457/18	457/18
Average Weight (kg/lb)	736/1619	736/1619	776/1487

High Pressure 240 BAR
3600PSI optional

HR22000/24000 /26000

Horizontal Windlass



*Gypsy centre varies with chain size

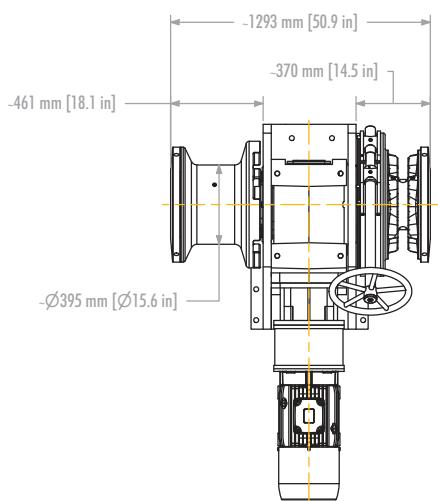

Single Capstan Single Gypsy

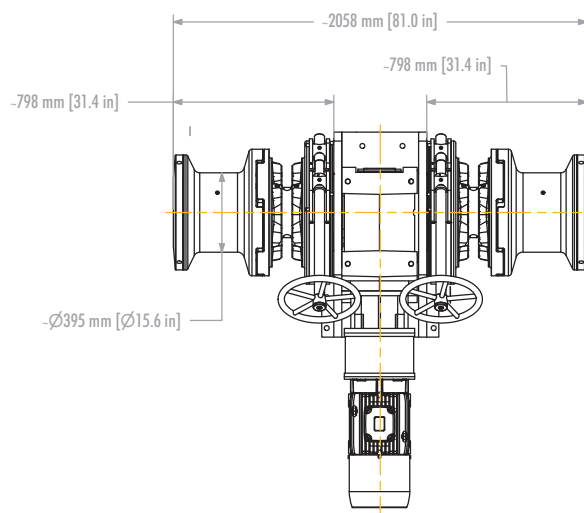

Twin Gypsy Twin Capstan

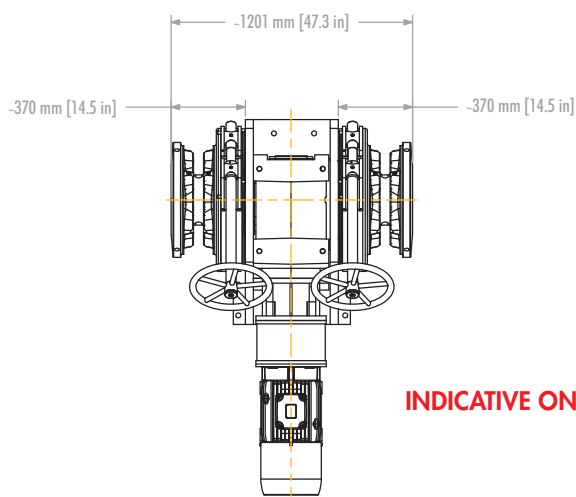
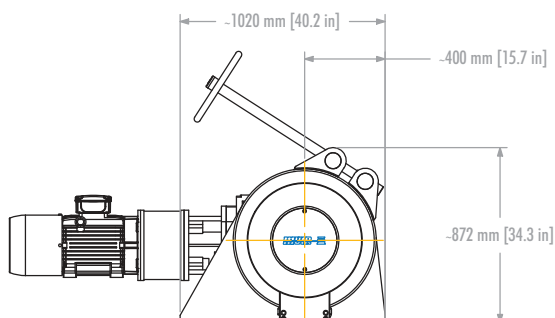

Twin Gypsy

INDICATIVE ONLY

PERFORMANCE CRITERIA

MODEL	HR22000	HR22000
Maximum Pull (kg/lb)	10000/22000	10000/22000
Continuous Pull (kg/lb)	7500 / 15500	7500 / 15500
Recommended Minimum Speed (m/pmin - f/pmin)	10 / 33	10 / 33
Maximum Recovery High Speed (m/pmin - f/pmin)	20 / 66	20 / 66
Power Supply	HYDRAULIC	AC
Input Power (kW)		Up to 18.5KW
Hydraulic Flow (l/pmin-USgpm)	65 / 17.2	
Maximum Flow (l/pmin-USgpm)	120 / 31.7	
Pressure (bar/PSI)	210/3045	
Maximum Pressure (bar/PSI)	250/3625	
Chain Size		
Short link up to		
Stud link up to	38mm U2+	38mm U2+
Brake Size	660/26	660/26
Average Weight (kg/lb)	1800/3960	1800/3960

INDICATIVE ONLY, SPECIFICATIONS ON REQUEST

VC4500

Powered Capstan

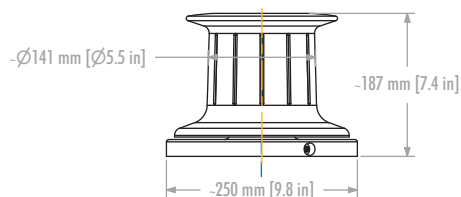

Standard Capstan

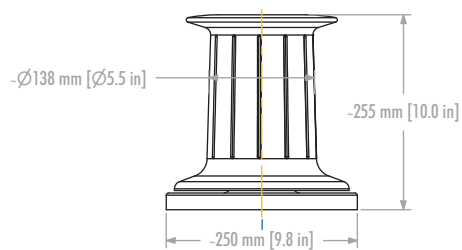

Tall Capstan

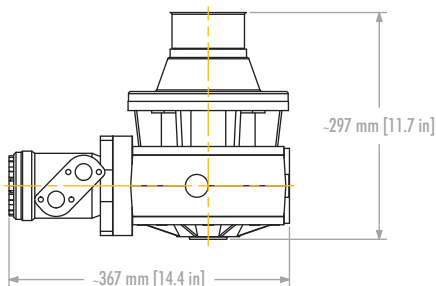

Right Angle Hydraulic Worm Drive

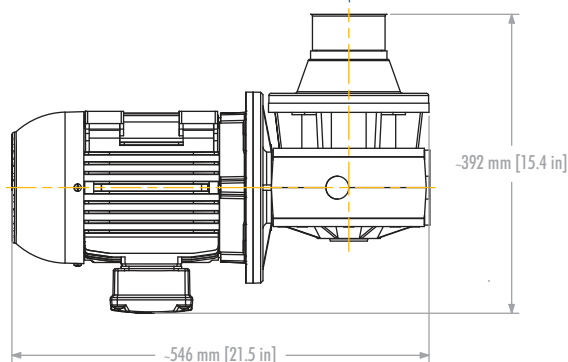

Right Angle Electric Worm Drive

PERFORMANCE CRITERIA INDICATIVE ONLY

MODEL	VC 4500	VC 4500	VC 4500	VC 4500
Maximum Pull (kg/lb)	2200/4840	2200/4840	2200/4840	2200/4840
Continuous Pull (kg/lb)	750/1650	1000/2200	1000/2200	1050/2300
Recommended Minimum Speed (m/pmin - f/pmin)	15/50	10/33	10/33	10/33
Maximum Recovery High Speed (m/pmin - f/pmin)		20/66	20/66	20/66
Power Supply	24V DC	3PH/50HZ	3PH/60HZ	HYDRAULIC
Input Power (kW)	2	2.2	2.2	
Hydraulic Flow (l/pmin-USgpm)				22/5.8
Maximum Flow (l/pmin-USgpm)				44/11.6
Pressure (bar/PSI)				175/2537
Maximum Pressure (bar/PSI)				200/2900
Average Weight (kg/lb)	62/136	85/187	85/187	56/123

High Pressure 240 BAR
3600PSI optional

VC6000

Powered Capstan

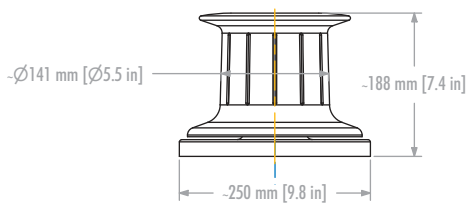

Standard Capstan

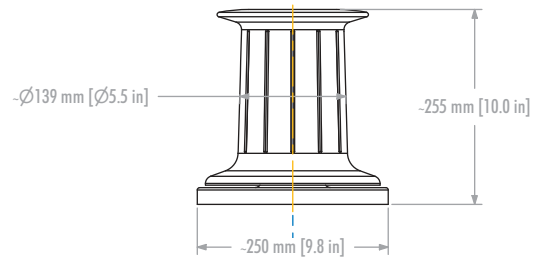

Tall Capstan

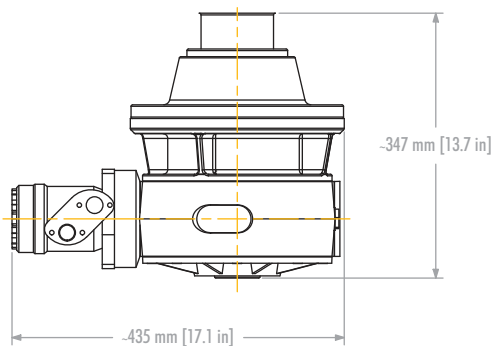

Right Angle Hydraulic Worm Drive

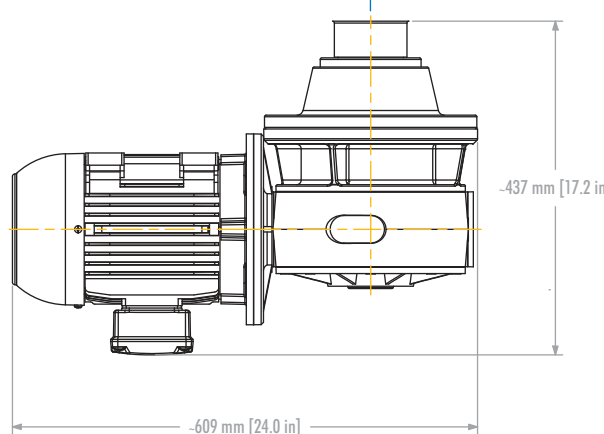

Right Angle Electric Worm Drive

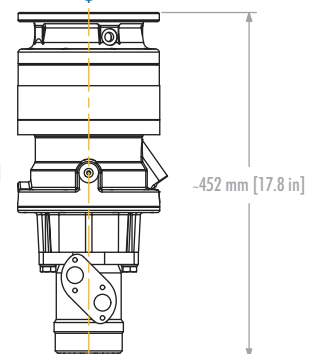

Inline Hydraulic Planetary Drive
*option available for extra cost

PERFORMANCE CRITERIA INDICATIVE ONLY

MODEL	VC 6000	VC 6000	VC 6000	VC 6000
Maximum Pull (kg/lb)	2600 / 5720	2600 / 5720	2600 / 5720	2900 / 6380
Continuous Pull (kg/lb)	1500 / 3300	1500 / 3300	1500 / 3300	2138 / 4703
Recommended Minimum Speed (m/pmin - f/pmin)	15 / 50	10/33	10/33	10/33
Maximum Recovery High Speed (m/pmin - f/pmin)		20 / 66	20 / 66	20/66
Power Supply	24V	3PH/50HZ	3PH/60HZ	HYDRAULIC
Input Power (kW)	3.5	3	3	
Hydraulic Flow (l/pmin-USgpm)				28/7.4
Maximum Flow (l/pmin-USgpm)				56/14.8
Pressure (bar/PSI)				175/2537
Maximum Pressure (bar/PSI)				200/2900
Average Weight (kg/lb)	90 / 198	122/268	122/268	83/182

High Pressure 240 BAR
3600PSI optional

VC8000/11000

Powered Capstan

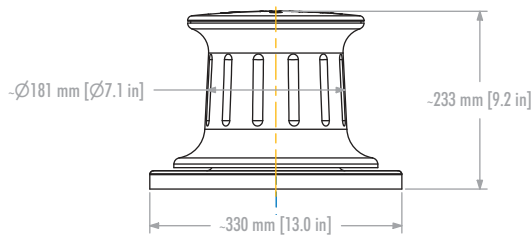

Standard Capstan

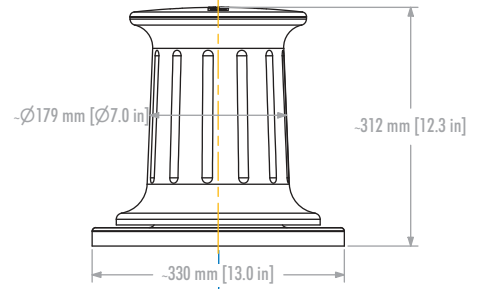

Tall Capstan

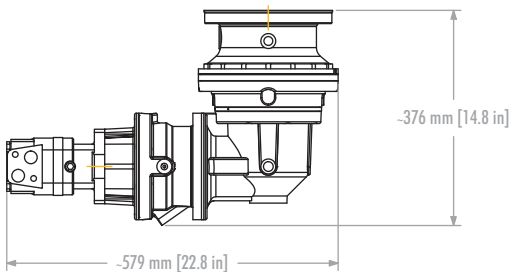

Right Angle Hydraulic Planetary Drive

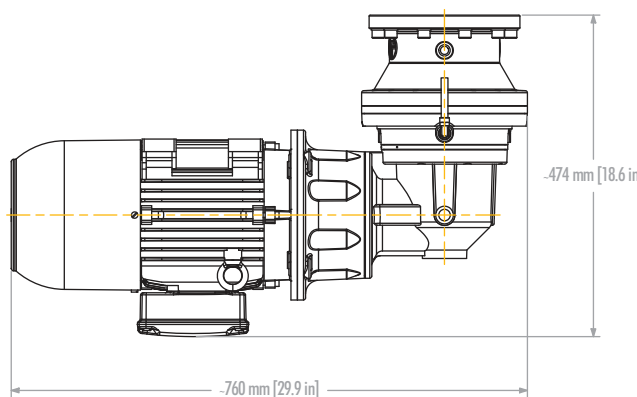

Right Angle Electric Planetary Drive

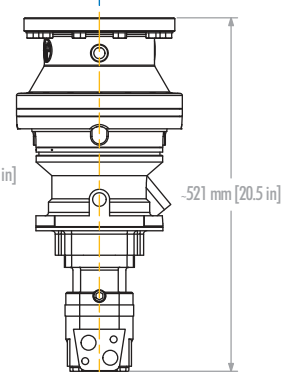

Inline Hydraulic Planetary Drive

PERFORMANCE CRITERIA INDICATIVE ONLY

MODEL	VC 8000	VC 8000	VC 11000	VC 11000
Maximum Pull (kg/lb)	3800 / 8360	3800 / 8360	5000 / 11000	5000 / 11000
Continuous Pull (kg/lb)	2200 / 4840	3000 / 6600	2600 / 5720	4140 / 9108
Recommended Minimum Speed (m/pmin - f/pmin)	10 / 33	10 / 33	10 / 33	10 / 33
Maximum Recovery High Speed (m/pmin - f/pmin)	20 / 66	20 / 66	20 / 66	20 / 66
Power Supply	3PH / 50HZ	HYDRAULIC	3PH / 50HZ	HYDRAULIC
Input Power (kW)	4/5.5		5.5/7.5	
Hydraulic Flow (l/pmin-USgpm)		28 / 7.4		30 / 7.9
Maximum Flow (l/pmin-USgpm)		56 / 14.8		60 / 15.8
Pressure (bar/PSI)		175 / 2537		175 / 2537
Maximum Pressure (bar/PSI)		200 / 2900		200 / 2900
Average Weight (kg/lb)	169 / 372	103 / 226	193 / 424	

High Pressure 240 BAR
3600PSI optional

VC13000/15000

Powered Capstan

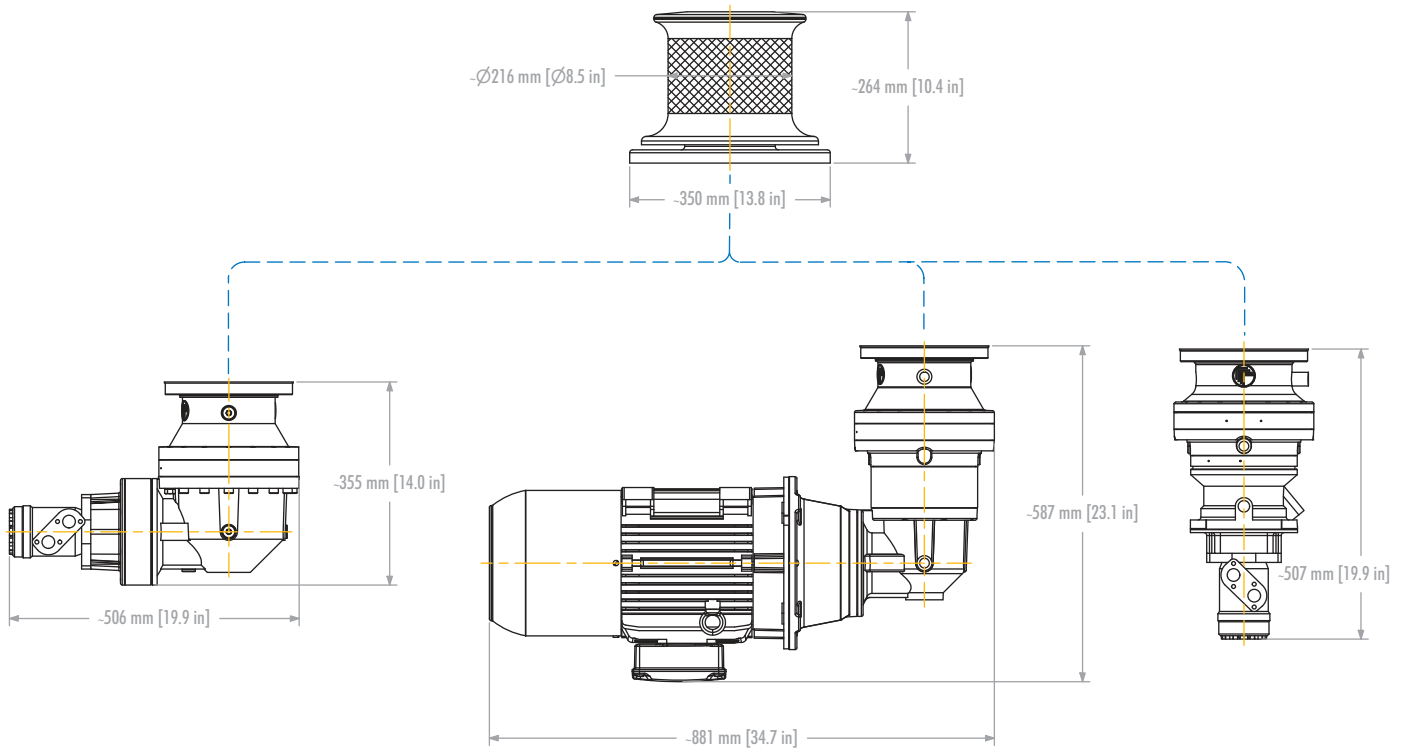

Right Angle Hydraulic Planetary Drive

Right Angle Electric Planetary Drive

Inline Hydraulic Planetary Drive

PERFORMANCE CRITERIA INDICATIVE ONLY

MODEL	VC13000/15000	VC13000/15000	VC13000/15000
Maximum Pull (kg/lb)	6818/15000	6818/15000	6818/15000
Continuous Pull (kg/lb)	3180 / 6966		3900 / 8580
Recommended Minimum Speed (m/pmin - f/pmin)	10/33	10/33	10/33
Maximum Recovery High Speed (m/pmin - f/pmin)	20/66	20/66	20/66
Power Supply	3PH/50HZ	3PH/60HZ	HYDRAULIC
Input Power (kW)	7.5/9.2	7.5/9.2	
Hydraulic Flow (l/pmin-USgpm)			30/7.9
Maximum Flow (l/pmin-USgpm)			60/15.8
Pressure (bar/PSI)			210/3045
Maximum Pressure (bar/PSI)			250/3625
Average Weight (kg/lb)	235/517	235/517	185/407

VC18000

Powered Capstan

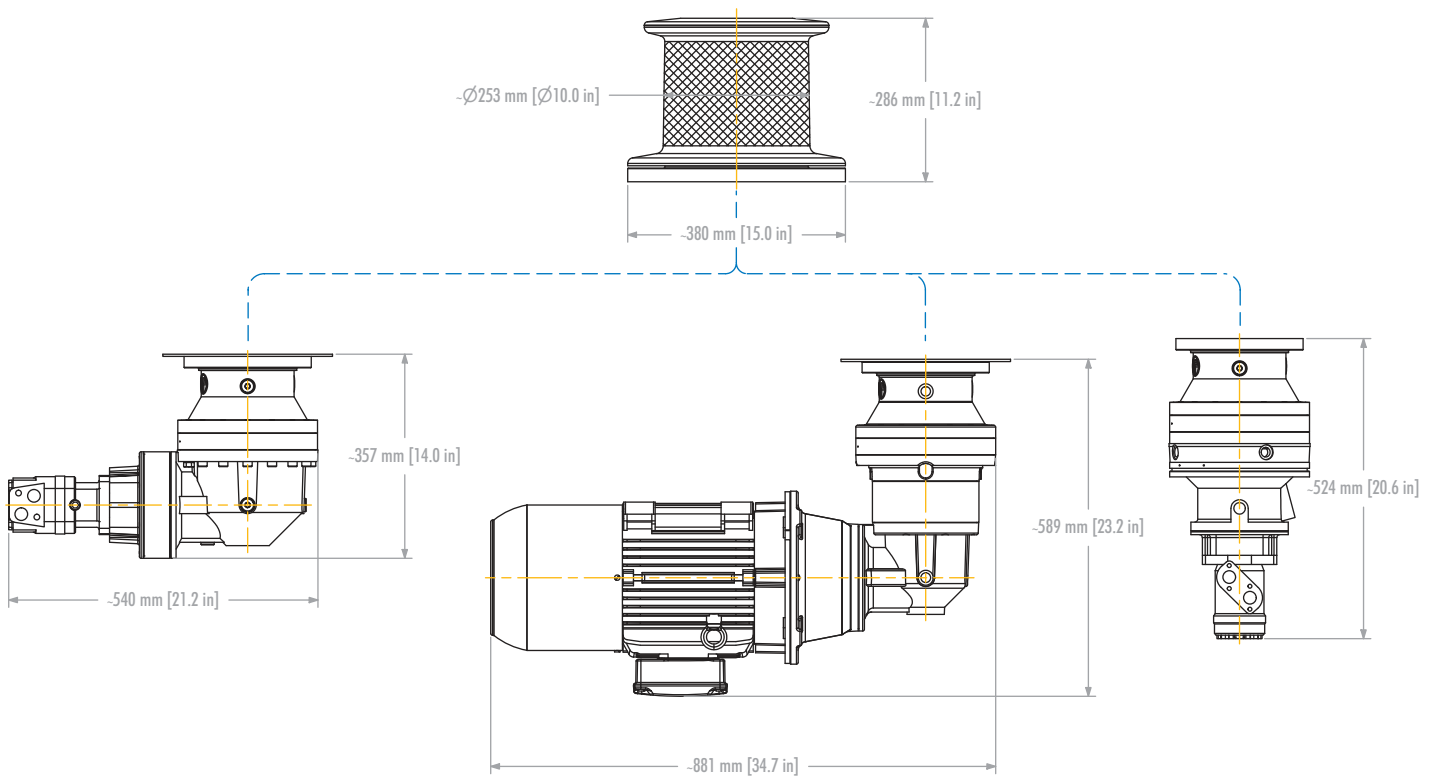

Right Angle Hydraulic Planetary Drive

Right Angle Electric Planetary Drive

Inline Hydraulic Planetary Drive

PERFORMANCE CRITERIA INDICATIVE ONLY

MODEL	VC 18000	VC 18000	VC 18000
Maximum Pull (kg/lb)	8181/18000	8181/18000	8181/18000
Continuous Pull (kg/lb)	5000 / 11000	5000 / 11000	5700 / 12540
Recommended Minimum Speed (m/pmin - f/pmin)	12/40	15/50	10/33
Maximum Recovery High Speed (m/pmin - f/pmin)			20/66
Power Supply	3PH/50HZ	3PH/60HZ	HYDRAULIC
Input Power (kW)	9.2 / 11	9.2 / 11	
Hydraulic Flow (l/pmin-USgpm)			36 / 9.5
Maximum Flow (l/pmin-USgpm)			72 / 19
Pressure (bar/PSI)			210 / 3045
Maximum Pressure (bar/PSI)			250 / 3625
Average Weight (kg/lb)	338/744	338/744	276/607

VC20000

Powered Capstan

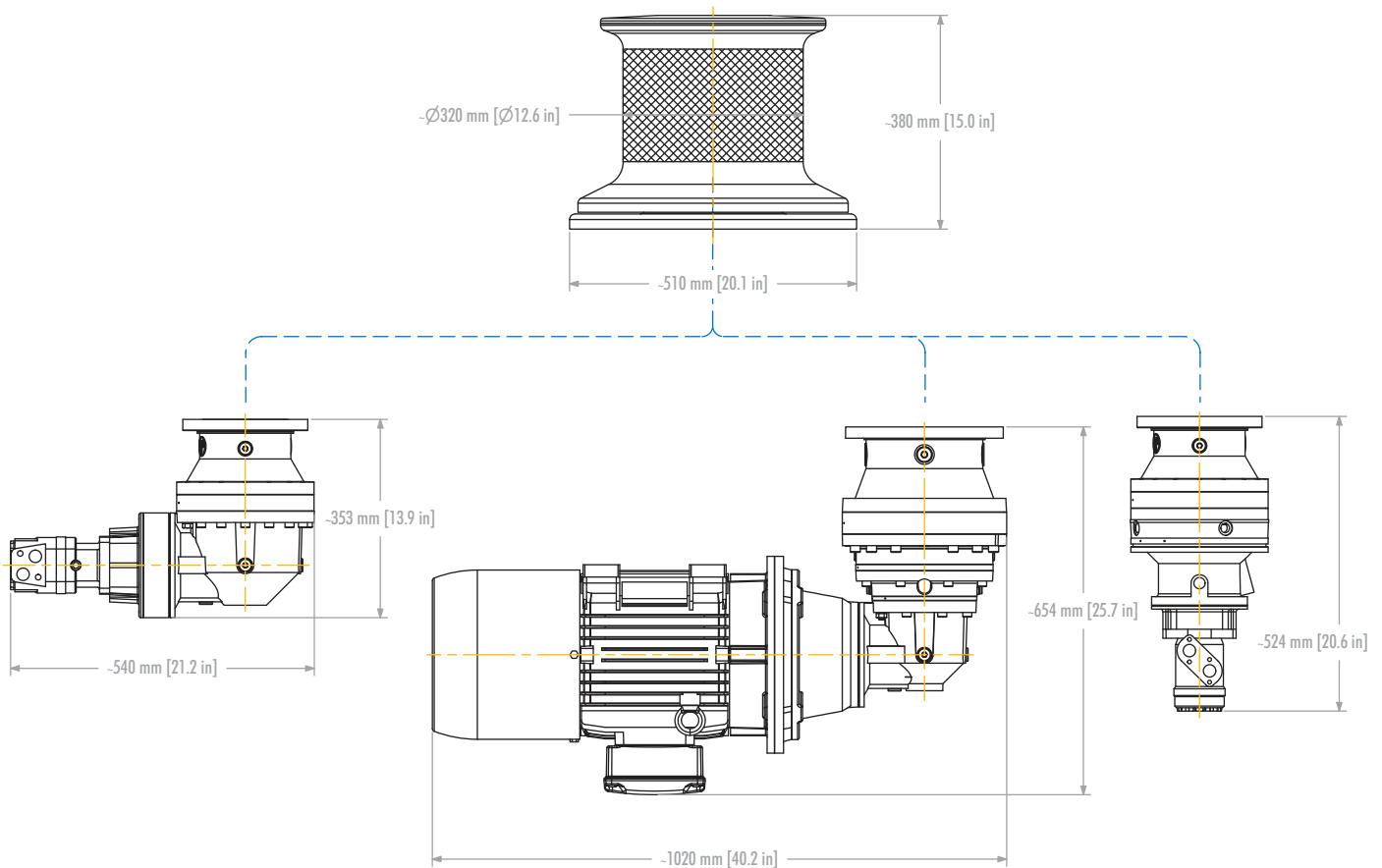

Right Angle Hydraulic Planetary Drive

Right Angle Electric Planetary Drive

Inline Hydraulic Planetary Drive

PERFORMANCE CRITERIA INDICATIVE ONLY

MODEL	VC 20000	VC 20000	VC 20000
Maximum Pull (kg/lb)	9090/20000	9090/20000	9090/20000
Continuous Pull (kg/lb)	5200 / 11440		6100 / 13420
Recommended Minimum Speed (m/pmin - f/pmin)	10 / 33	10 / 33	10 / 33
Maximum Recovery High Speed (m/pmin - f/pmin)	20/66	20/66	20/66
Power Supply	3PH/50HZ	3PH/60HZ	HYDRAULIC
Input Power (kW)	9.2 / 11	9.2 / 11	
Hydraulic Flow (l/pmin-USgpm)			40/10.6
Maximum Flow (l/pmin-USgpm)			80/21.2
Pressure (bar/PSI)			210/3045
Maximum Pressure (bar/PSI)			250/3625
Average Weight (kg/lb)	468/1030	468/1030	408 / 897

VC22000

Powered Capstan

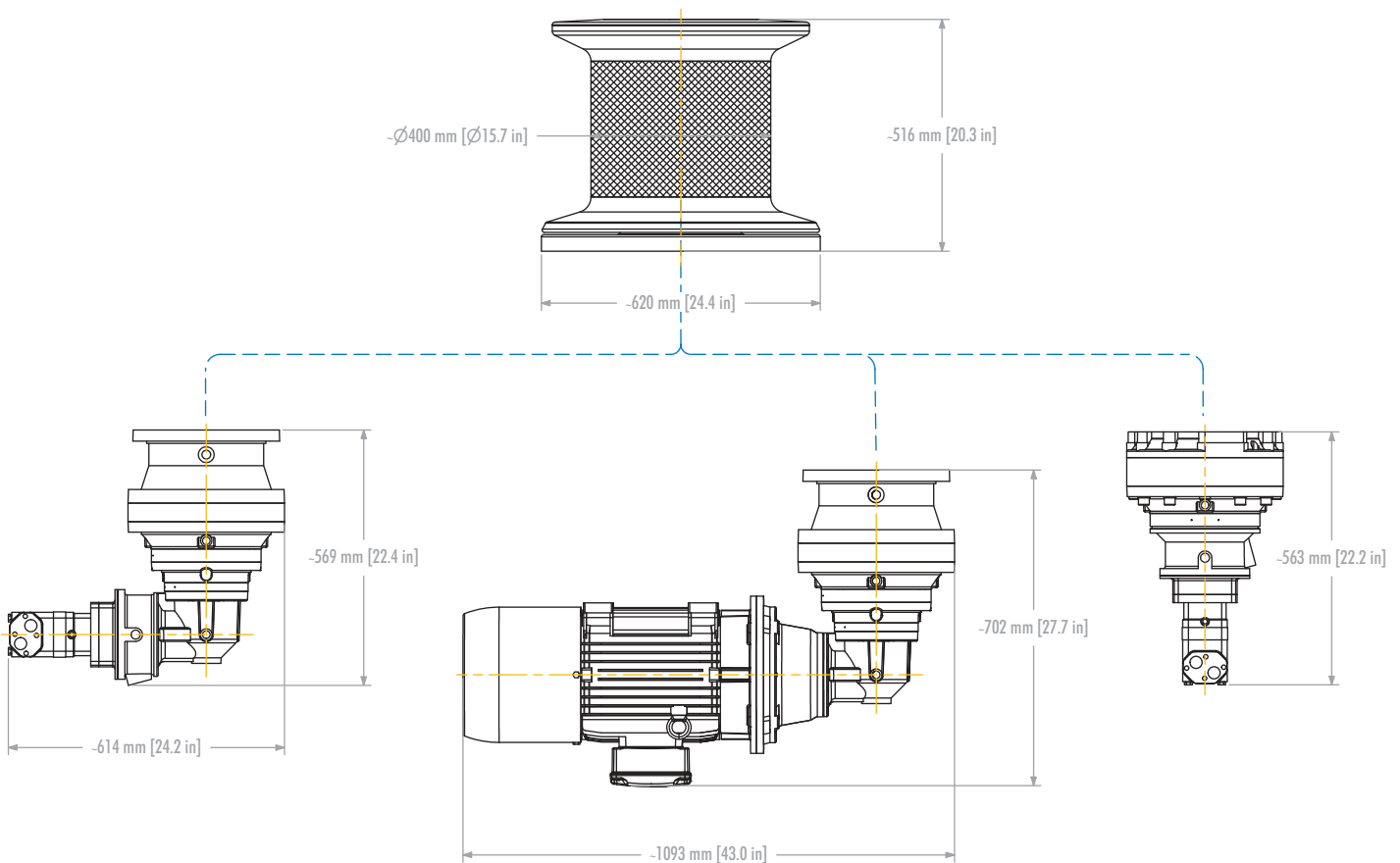

Right Angle Hydraulic Planetary Drive

Right Angle Electric Planetary Drive

Inline Hydraulic Planetary Drive

PERFORMANCE CRITERIA INDICATIVE ONLY

MODEL	VC 22000	VC 22000	VC 22000
Maximum Pull (kg/lb)	10000/22000	10000/22000	10000/22000
Continuous Pull (kg/lb)	6060 / 13332		7200 / 15840
Recommended Minimum Speed (m/pmin - f/pmin)	10/33	10/33	10/33
Maximum Recovery High Speed (m/pmin - f/pmin)	20/66	20/66	20/66
Power Supply	3PH/50HZ	3PH/60HZ	HYDRAULIC
Input Power (kW)	11 / 15	11 / 15	
Hydraulic Flow (l/pmin-USgpm)			48/12.7
Maximum Flow (l/pmin-USgpm)			96/25.4
Pressure (bar/PSI)			210/3045
Maximum Pressure (bar/PSI)			250/3625
Average Weight (kg/lb)	770/1694	770/1694	645/1419

VC24000

Powered Capstan

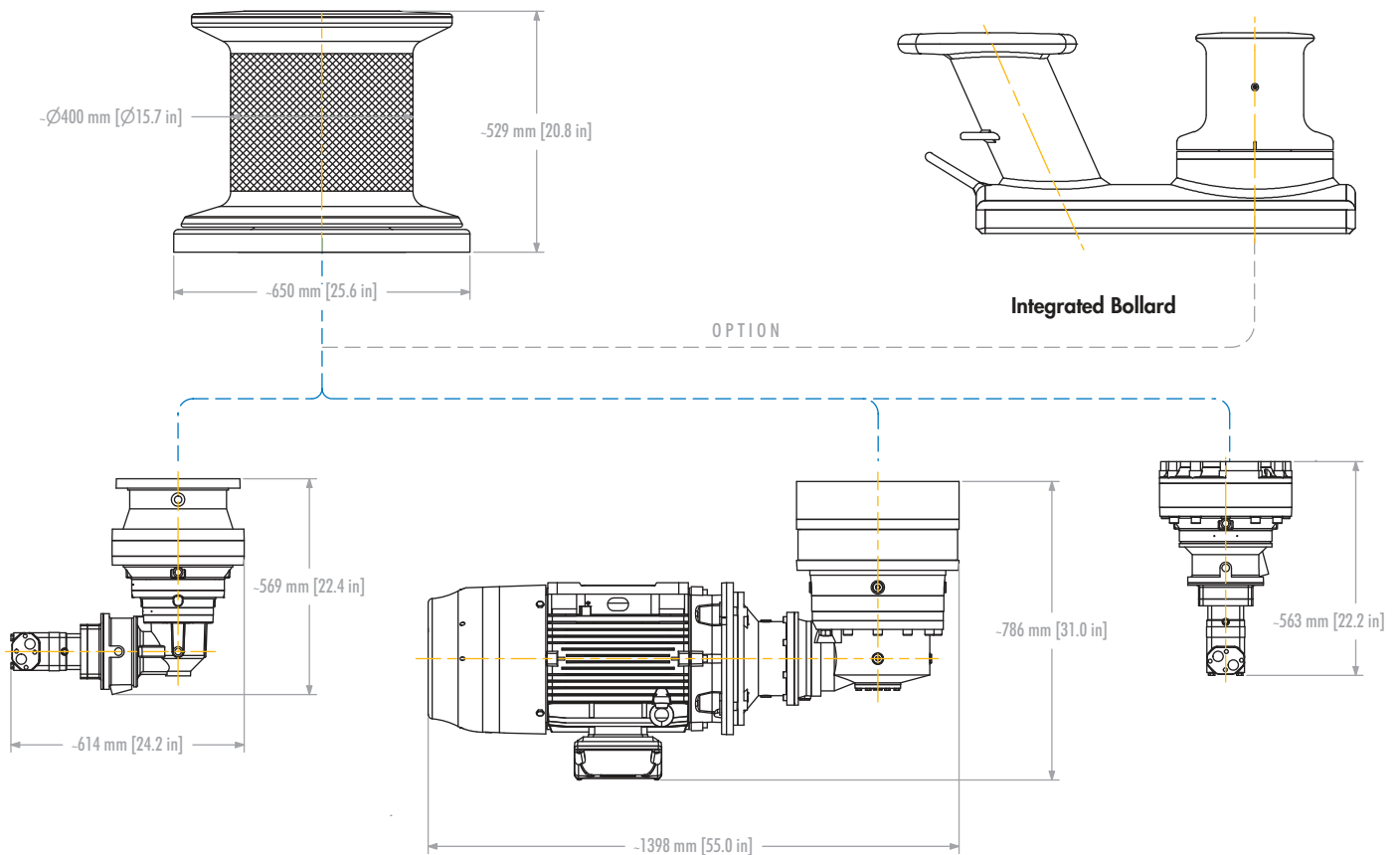

Right Angle Hydraulic Planetary Drive

Right Angle Electric Planetary Drive

Inline Hydraulic Planetary Drive

PERFORMANCE CRITERIA INDICATIVE ONLY

MODEL	VC 24000	VC 24000	VC 24000
Maximum Pull (kg/lb)	11000/24000	11000/24000	11000/24000
Continuous Pull (kg/lb)	7000 / 15400		8400 / 18480
Recommended Minimum Speed (m/pmin - f/pmin)	10/33	10/33	10/33
Maximum Recovery High Speed (m/pmin - f/pmin)	20/66	20/66	20/66
Power Supply	3PH/50HZ	3PH/60HZ	HYDRAULIC
Input Power (kW)	15 / 18.5	15 / 18.5	
Hydraulic Flow (l/pmin-USgpm)			48/12.7
Maximum Flow (l/pmin-USgpm)			96/25.4
Pressure (bar/PSI)			210/3045
Maximum Pressure (bar/PSI)			250/3625
Average Weight (kg/lb)	955 / 2101	955 / 2101	940 / 2068



CHAIN STOPPERS

CHAIN SIZE SHORT LINK	A	B	C	D	E
10mm	112	150	88	28	44
13mm	130	185	111	33, 32	54
16mm	197	235	138	43	69.5
	198	238	143	41	70
	192	235	136	42	70
16mm	198	238	136	42	70
	CHAIN SIZE STUD LINK				
	209	235	138	43	82
16mm	193	236	143	42	82
	209	238	143	42	82
17.5mm, 19mm	230	285	207	50	94
	230	285	202	50	94
20.5mm, 22mm, 24mm	270	300	205	65	116
20.5mm, 22mm	270	300	205	54	116
24mm, 26mm	280	280	255	71	110
28mm	310	375	256	55	134
34mm	350	385	275	50	160
38mm	388	460	350	76	180
38mm < 50mm			TBA		

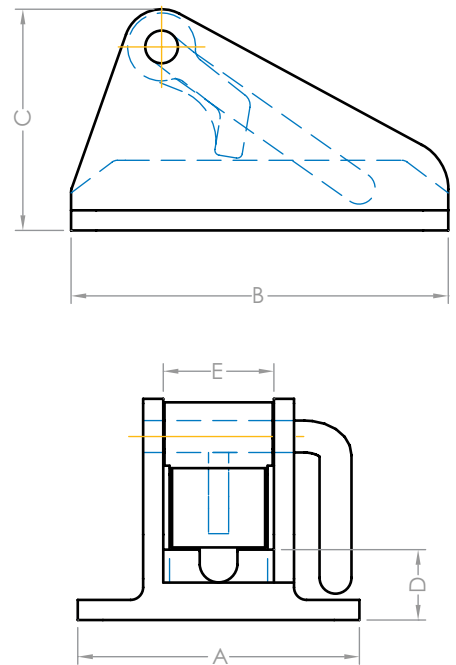

Chain stoppers are strongly recommended for safe anchoring to protect and remove load from the windlass when at anchor, and to prevent accidental free fall of the anchor while under way. The hinged pawl allows the chain to be pulled up automatically, and is easily disengaged to deploy the anchor. To suit all chain types up to 50mm (1 31/32") with optional finishes in chromed bronze, traditional polished bronze, highly polished or bead blasted 316 stainless steel.

CHAIN STOPPER DEVIL CLAW

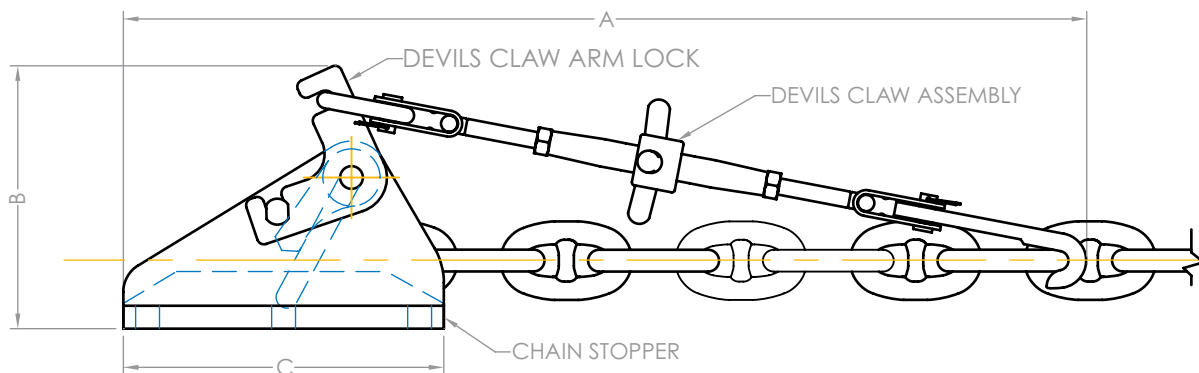

CHAIN	A	B
10mm	472	126
13mm	524	1632
14mm- 16mm	688	199
17.5mm-19mm	841	248
20.5mm- 24mm	857	280
24mm +	TBA	

Following the same principal of the conventional chain stoppers we combine a separate devil claw, this unique arrangement offers additional safety. The devil claw hooks onto the chain and provides tension on the chain while the anchor is stowed ensuring additional hold while underway. The devil claw can be easily removed or simply secured off to the side. The combined set provided increased safety. Available to suit any chain size, and finished in either chromed bronze, traditional polished bronze, highly polished or bead blasted 316L stainless steel.

HIGH PROFILE CHAIN STOPPER DEVIL CLAW ROLLER

Ideally suited when space is limited, these compact units remove load from the windlass, secure the stowed anchor and facilitate the chain transition. Finished in highly polished or bead blasted 316L stainless steel. The devil claw is used to pull "home" the stowed anchor to prevent movement when travelling.

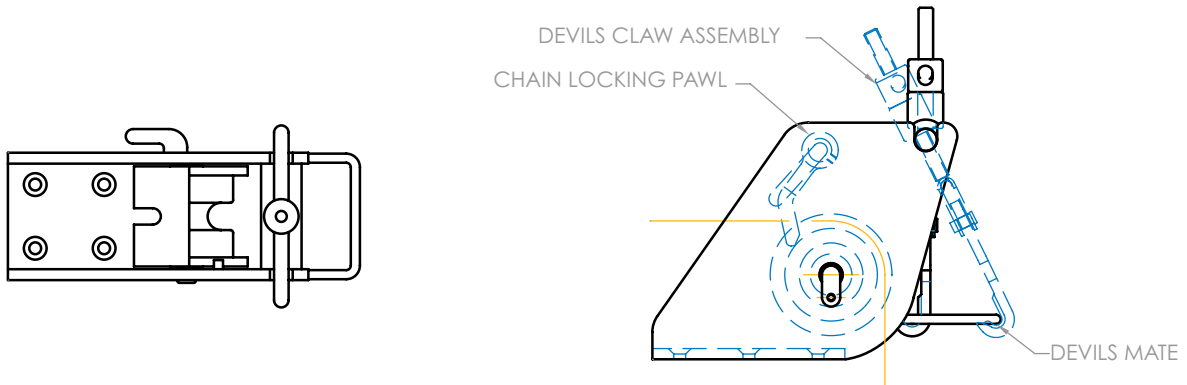

Available up-to 22mm U2

LOW PROFILE CHAIN STOPPER DEVILS CLAW ROLLER

These heavy duty units provide excellent protection for the windlass against stress and strain, with the added benefit of an integrated roller for smooth retrieval and deployment of the anchor rode. These models are available to accommodate chain up to 50mm, and is available in highly polished or bead blasted 316L stainless steel with four pocket bronze chain roller. The devil claw is used to pull "home" the stowed anchor to prevent movement when travelling.

UP TO 26MM

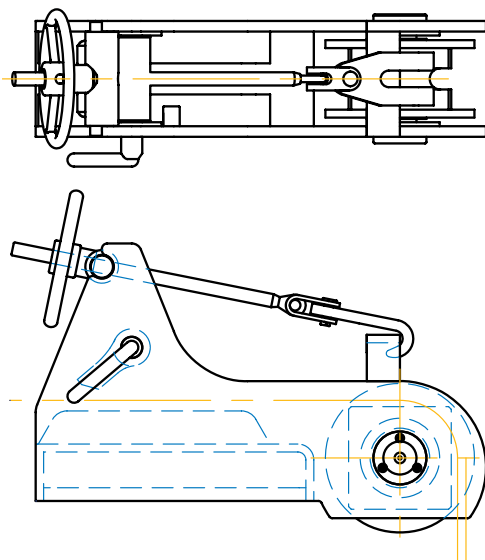

UP TO 50MM

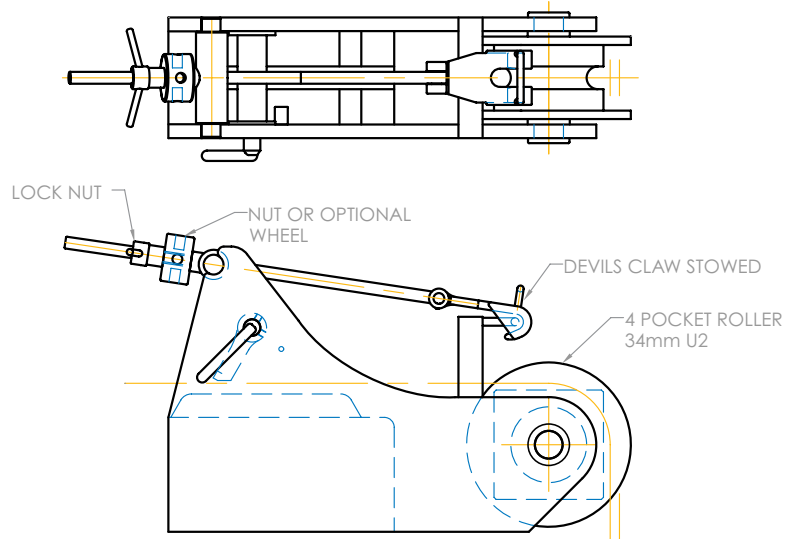



ANCHORING SYSTEMS ACCESSORIES

CHAIN COMPRESSOR

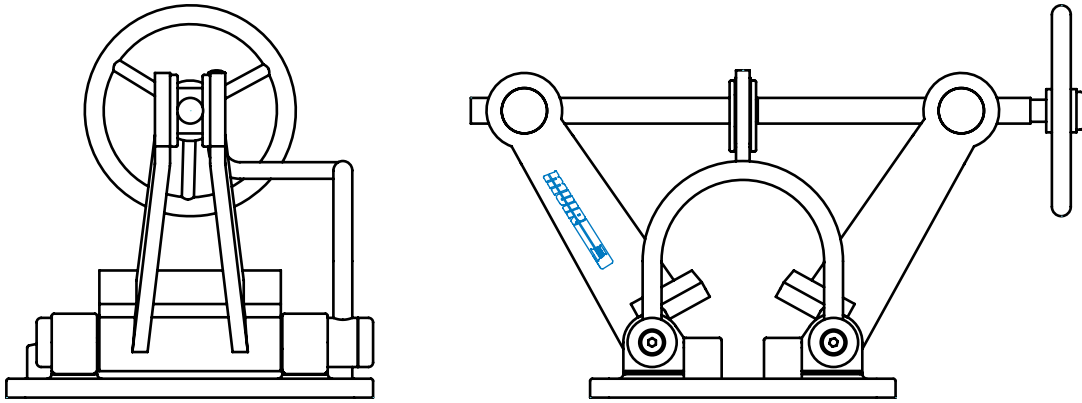

CHAIN COMPRESSOR DEVIL CLAW ROLLER WITH BASE

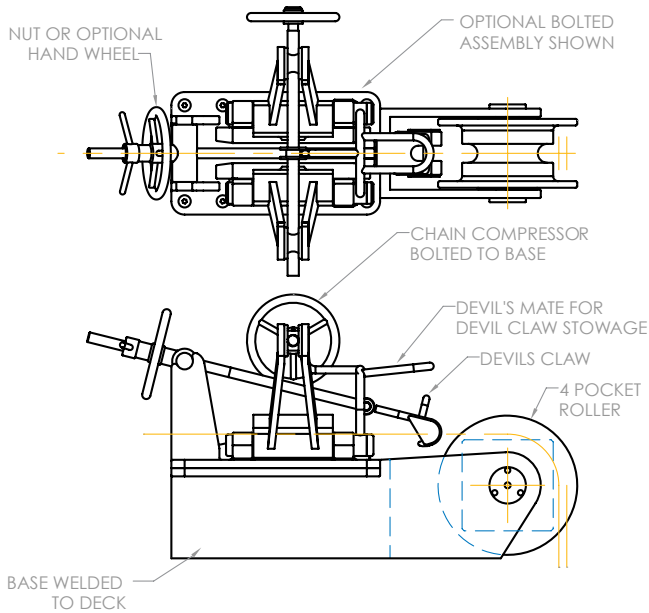

Suited to larger yachts and chain sizes, chain compressors protect the windlass from unnecessary load and strain by transferring the load of the chain through two clamping arms when at anchor. Tensioning of the hand wheel tightens the arms clamping the chain securely. A devils claw system is incorporated into the assembly and is applied when the anchor is stowed, as opposed to when at anchor, to ensure the anchor cannot be accidentally released while under way. The windlass clutch and band brake should be engaged as well for added safety.. Finished in choice of chromed bronze, traditional polished bronze, highly polished or bead blasted 316L stainless steel.

These units will suit chain up to 50mm U2.

Variations in this range include Chain Compressor Devil Claw Roller Arrangement and Integral Chain Compressor Devil Claw Roller Arrangement (raised base optional).

ROLLER WITH FLANGES

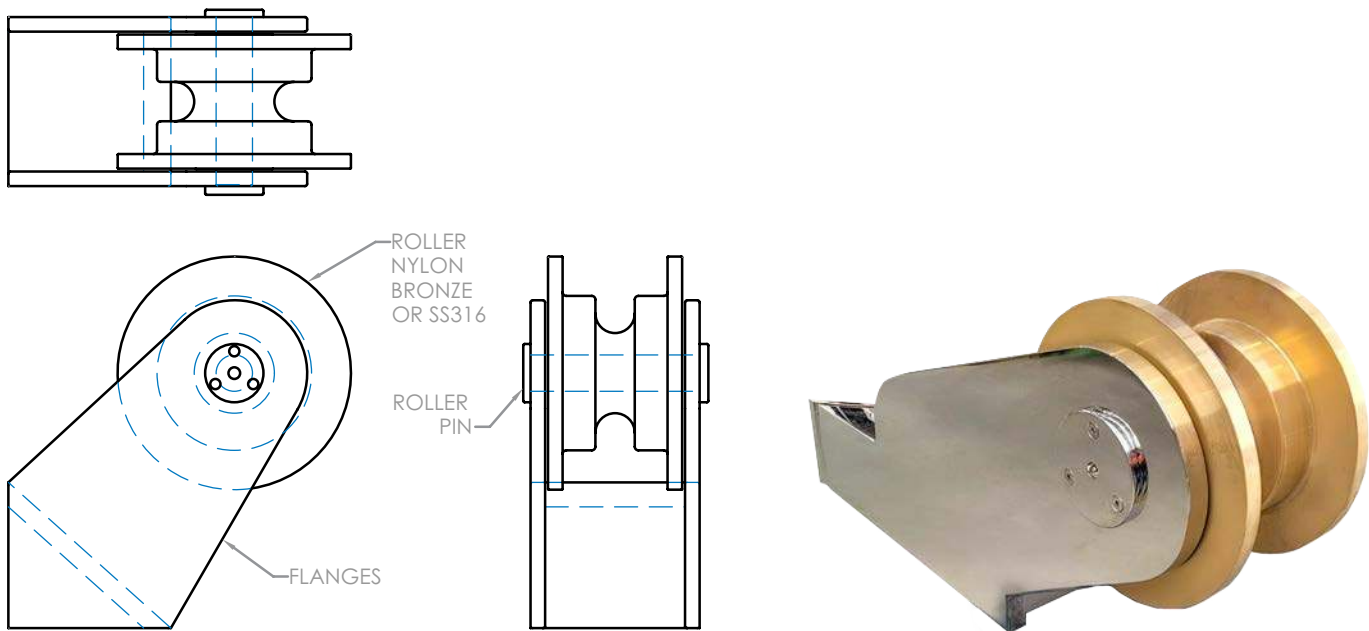

Muir can supply a range of roller and flange solutions for both bow rollers and chain return rollers. Rollers are available in bronze, bronze chrome, stainless steel or nylon. Flanges available in stainless steel, steel or aluminium.

CURVED CHAIN PIPE ROLLER

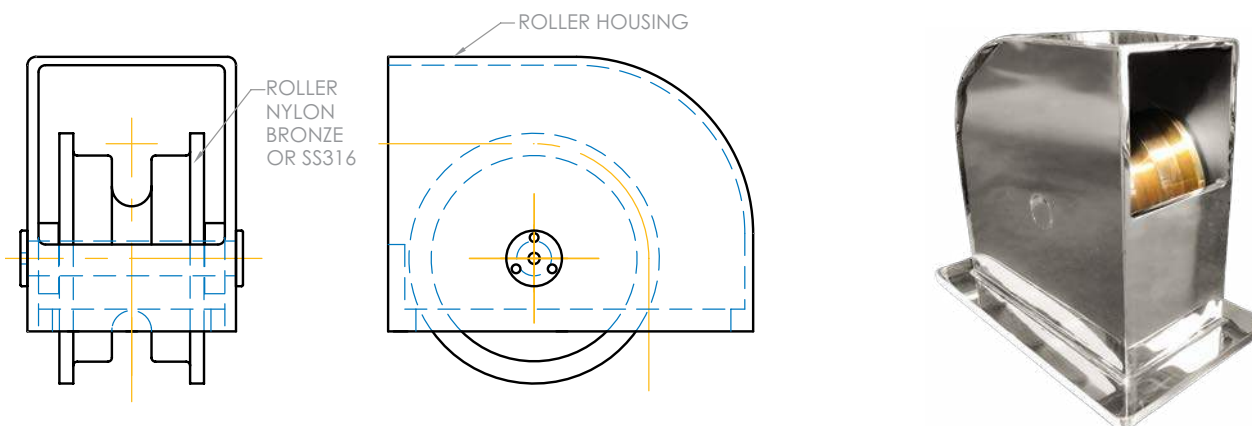

Chain Pipe Rollers facilitate smooth chain transition between the winch equipment and anchor locker spurling pipe. Available for all chain sizes, are finished in highly polished stainless steel. Rollers are available in bronze or nylon.

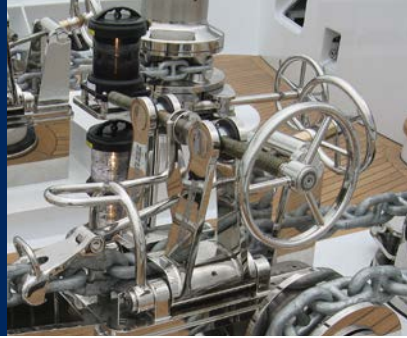

ANCHORING SYSTEMS ACCESSORIES

TURNING BLOCK FAIRLEAD

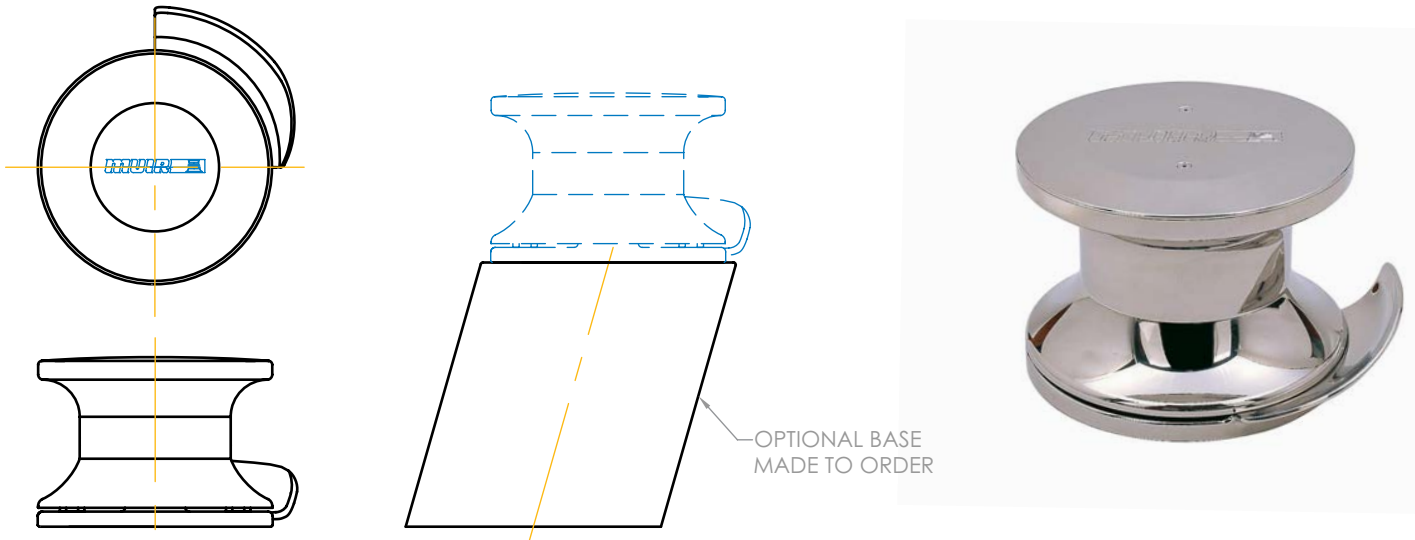

Muir free wheeling turning blocks aid and assist in the prevention of chafing and rubbing of mooring lines, and for rapid or severe alignment to capstans or windlasses. Equipped with double row sealed bearings, the robust construction ensures they are capable of withstanding the breaking strain of the line. Available in chrome bronze, traditional polished bronze or highly polished stainless steel, these units are custom built to suit particular requirements of the anchoring system components specified, and can be supplied as a pocket roller for anchor chain. Various sizes available.

INTEGRATED BOLLARD CAPSTAN

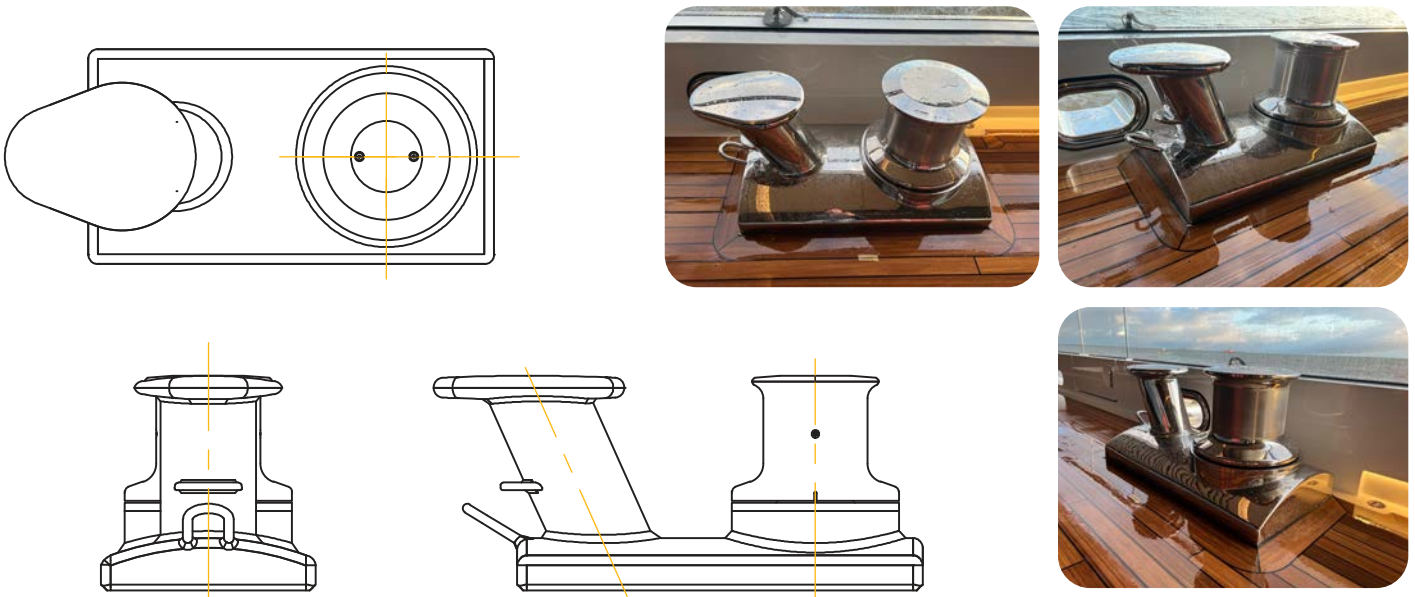

Available in all sizes from VC6000 and up, the integrated mooring bollard capstan reduces overall mooring system footprint and is designed with a strengthened base to meeting the static load requirements of a standard mooring bollard. Hand fabricated from high quality Stainless Steel plate, and available in polished, blasted or painted finishes. Can be customised to match existing bollard designs on your vessel if required.

ANCHORING SYSTEMS ACCESSORIES



PORTABLE HAND PENDANT CONTROL UNIT

Weatherproofed solid-state modules give you complete control of your winch/windlass operations from anywhere on your boat enabling the operator to visually check the anchor under retrieval. Simply plug into the socket fitted on the foredeck, at the helm or cockpit. Available for all windlass and capstan models. Radio control units are available providing total freedom for operation.

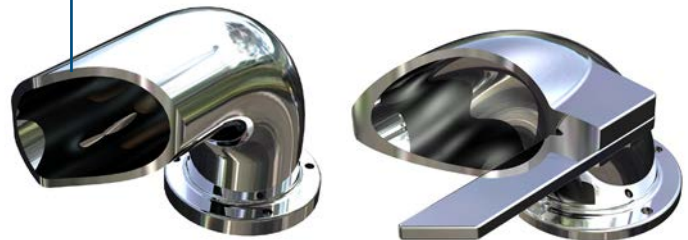

CHAIN PIPE (CP)

Facilitate the feeding of the anchor rode through into the locker. Available in 316L stainless steel, chrome bronze or polished bronze finish, to suit all models and chain up to 30mm U2 (1 3/16").



CHAIN PIPE ROLLERS (CPR)

Facilitate smooth transition of anchor rode from the chain gypsy to stowage below deck and provide accurate chain placement. Available in polished 316L stainless steel, rollers bronze or nylon, to suit all windlass models and chain up to 50mm (1 31/32").

ANCHORING SYSTEMS ACCESSORIES



CONTROL CABINETS

Configured to suit all windlass voltages and applications in single, two or variable speed and for control of single or multiple windlasses and capstans. Finished in stainless steel or various coloured coatings, these units can be supplied to comply with classification requirements.



MUIR CHAIN + ANCHORS

A wide range and grades of galvanized, black, high tensile, studlink and shortlink chain available. Tested to comply with mechanical properties and ISO standards. Studlink chain can be supplied with test certificates to comply with all classification society requirements.



FOOTSWITCHES

Heavy duty up down switches fitted standard with poly flip top or optional stainless steel or bronze covers with hardwearing U.V. stabilised neoprene boot. Suitable for 12 and 24 volt applications, nickel plated copper contacts provide corrosion free operation. Various colours, finishes and low amp models available.



AUTOANCHOR WINDLASS CONTROLS AND CHAIN COUNTERS



AA560 PANEL MOUNT CHAIN COUNTER AND WINDLASS CONTROL

Features:

- Graphic LCD featuring intuitive user interface
- Adjustable back lit display in feet, metres or fathoms
- Preset stopping point on retrieval
- One touch function to deploy and retrieve a preset length of rode
- Displays windlass speed and direction
- Safety lock helps protect against accidental windlass deployment
- Logs windlass operation hours to help ensure regular windlass maintenance
- Weather cover and choice of black or grey console
- Operates in parallel with all AutoAnchor products, toggle switches, foot switches or other control equipment

AA710 WIRELESS HAND HELD REMOTE CONTROL WITH CHAIN COUNTER



AA710 WIRELESS HAND HELD REMOTE CONTROL WITH CHAIN COUNTER

All the features of the AA560 plus options to control thrusters and other deck equipment

- Kit includes 1 remote console and 1 base station.
- Each base station has 6 outputs - up to 3 base stations and consoles can be combined in one system.
- Console displays rode count plus signal strength and battery level
- Control 2 windlasses from a single remote console
- Operate a dual speed windlass
- Shockproof
- 2.4Ghz ISM band
- Meets IP67 waterproof standard
- IEEE802.15.4 compliant
- Console holder and protective cover
- High level wireless transmission security with unique ID
- Ergonomic shape with lanyard connector
- Rubber over moulding for grip and non slip protection
- Antenna available if wireless communication is impeded

AA730 (same features as AA710) but also features

Rugged cable and connectors with:

- Moulded plug and socket rated to IP67
- 2m flying-lead from socket for better connectivity
- Gold plated contacts on plug and socket to reduce corrosion
- Socket sealing cap



AA730 CABLE REMOTE CONTROL WITH COUNTER



AA802 CHAIN COUNTER FOR GLASS BRIDGE MONITORING

The latest in electronic windlass monitoring from the helm. This black box chain counter is designed to integrate with an on board computer or electronic monitoring system. It displays the count in feet, metres or fathoms. Has a docking alarm and logs windlass operating hours for maintenance. All software protocols are supplied.

ANCHORING SYSTEM ARRANGEMENTS – EXAMPLE A

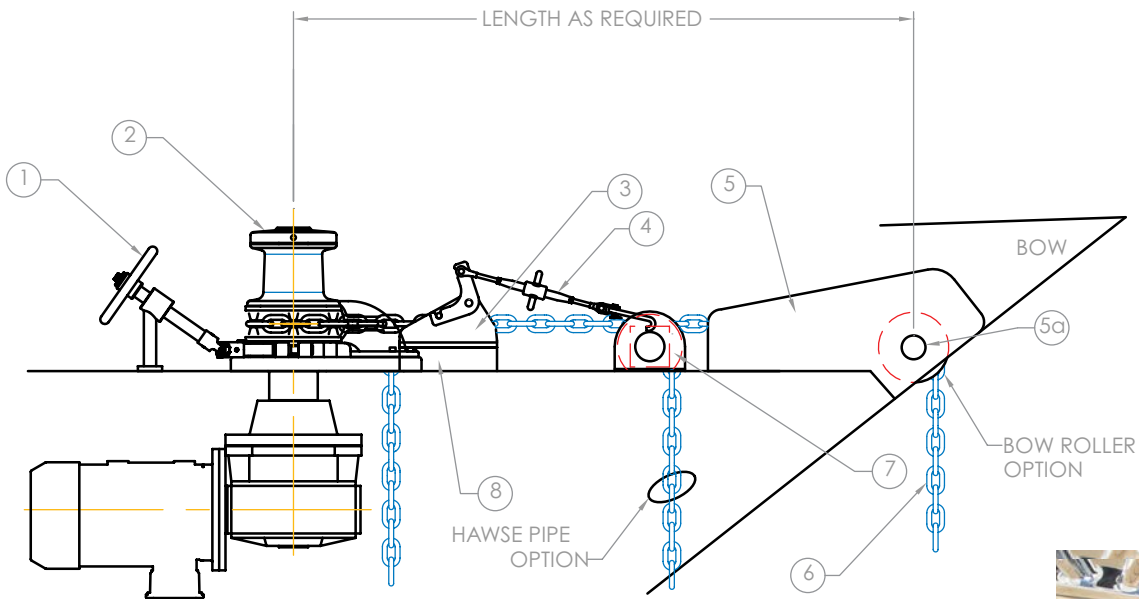

- | | | | |
|---|------------------------------------|----|--|
| 1 | OPTIONAL 45 DEG BRAKE HANDLE | 5A | CHAIN ROLLER – STAINLESS STEEL |
| 2 | VRC4500 WINDLASS | 6 | CHAIN AND ANCHOR SYSTEMS |
| 3 | CHAIN STOPPER - BRONZE | 7 | CHAIN ROLLER |
| 4 | DEVILS CLAW KIT WITH ARM LOCK | 8 | CHAIN STOPPER SPACER – STAINLESS STEEL |
| 5 | CHANNEL ASSEMBLY - STAINLESS STEEL | | |



ANCHORING SYSTEM ARRANGEMENTS – EXAMPLE B

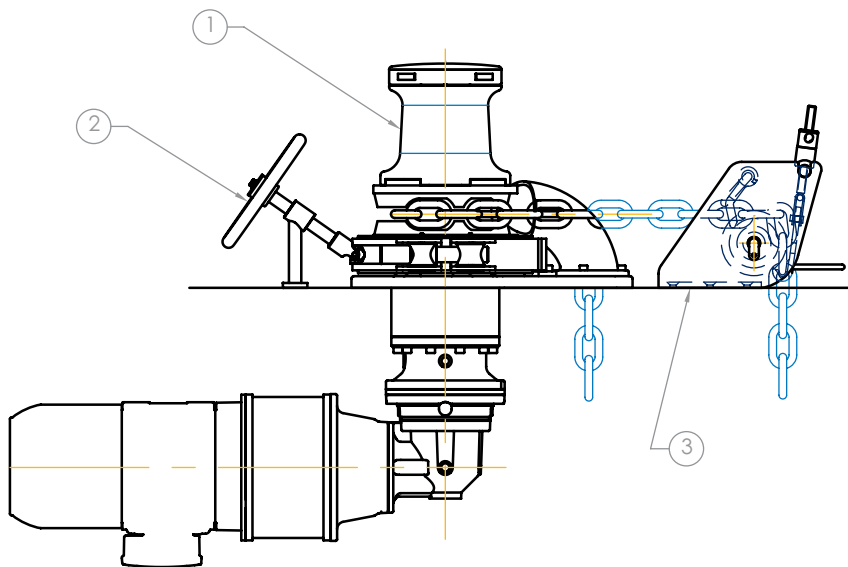

- | | |
|---|--|
| 1 | VRC8000/11000 WINDLASS SHOWN |
| 2 | 35° BRAKE ASSEMBLY |
| 3 | HIGH PROFILE ROLLERLOCK / DEVILS CLAW ASSEMBLY |





ANCHORING SYSTEM ARRANGEMENTS – EXAMPLE C

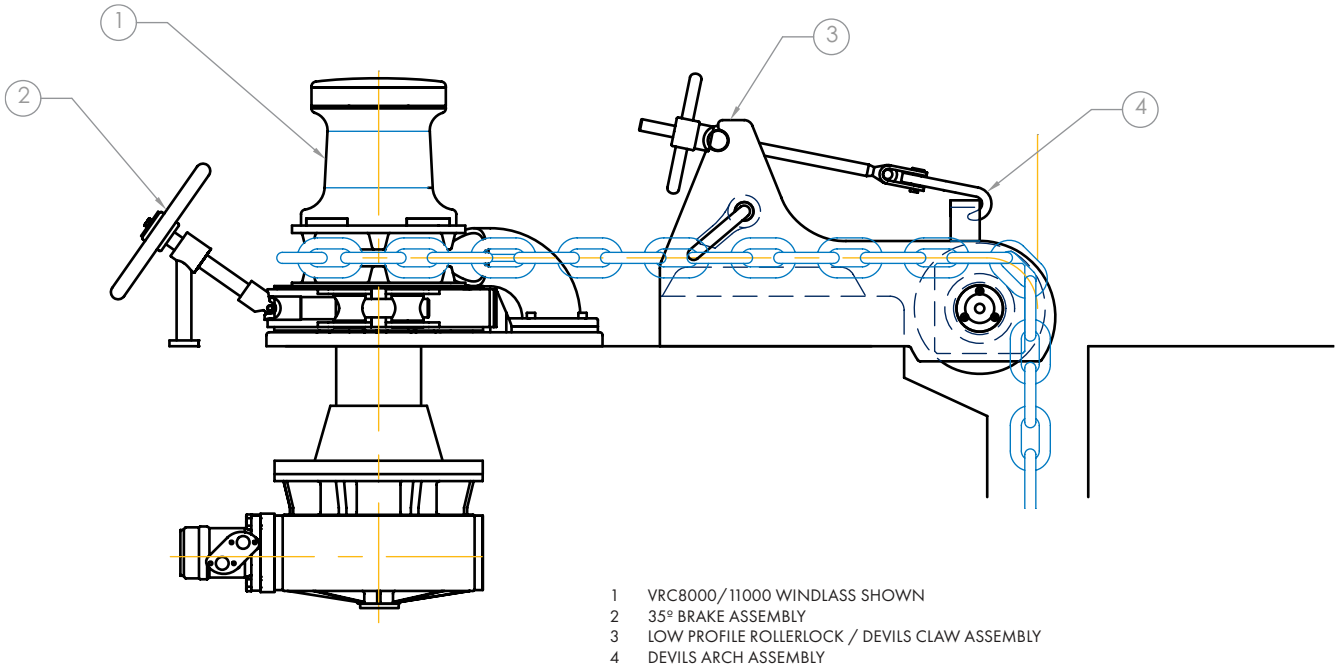

ANCHORING SYSTEM ARRANGEMENTS – EXAMPLE D

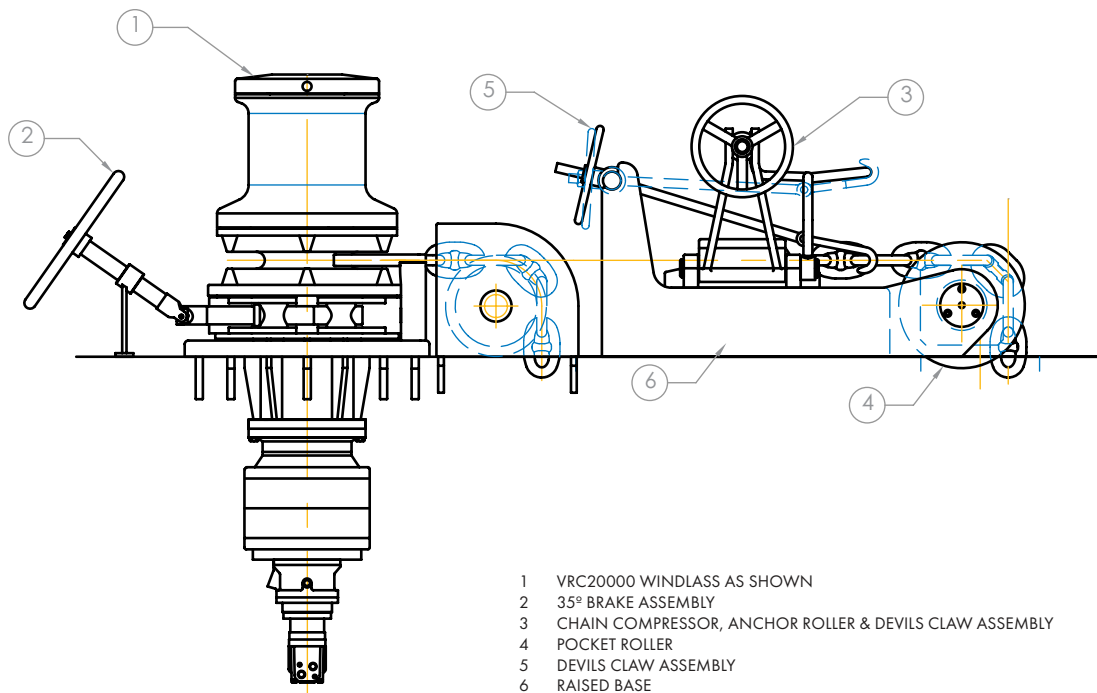





GLOSSARY OF TERMS



AMPS Workload – determined as up to the maximum amps.

Anchor Rode – the line that secures the anchor to the vessel, consisting of either rope, chain or a combination of rope and chain.

Bollard – an upright round post with projecting arm, for belaying and snubbing dock or anchor lines.

Bridle – chain stopper/compressor, devils claw. Located between the winch and bow roller. Secures chain and takes load off the winch/windlass.

Capstan – drum, rope drum. The capstan is used for hauling rope.

Chain Locker – the storage compartment in which the chain occupies.

Chain Pipe/Chain Pipe Roller – chain pipe that anchor rode feeds through into locker.

Chain Stopper – located between the winch and the bow roller (or hawse pipe), it secures the chain and anchor and takes the load off the winches.

Continuous Pull – is nominally 50% of the maximum pull. (Also workload)

Displacement – the amount of water displaced by a floating vessel, usually measured in tonnes.

Draft (Draught) – is the vertical distance between the waterline and the bottom of the hull (keel), with the thickness of the hull included.

Fixed drive – direct couple from transmission to gypsy/capstan.

Free Fall – release of clutch manually releases the chain to freefall without power.

Gypsy – chain wheel (Wild Cat) is the sprocket around which the chain is wrapped on the windlass.

Hauling – weighing, lifting. The operation of lifting anchor, rope or chain.

Horizontal windlass/winch – drive shaft, capstan and gypsy are located horizontally to the deck.

Inline drive – powerful and efficient integrated gearbox and motor.

Maximum Pull – is the peak intermittent pull.

Max Line Speed – maximum speed the anchor rode could be retrieved at.

Spurling Pipe – mounted below deck it is the means to guide the chain into the anchor locker.

VFD (Variable Frequency Drive) – an electronic device used to control the AC motors by varying the alternating frequency of the voltage supplied to the motor from a constant source.

Vertical windlass/winch – drive shaft, capstan and gypsy are located vertically to the deck.

Weigh – to weight anchor (to lift - anchor).

Windlass – a vertical or horizontal mechanical apparatus manually, electrically or hydraulically operated for pulling or hoisting anchor and cable (chain or synthetic rope), incorporating a circular chain wheel or gypsy normally with a minimum of five pockets into which anchor chain links fit snugly.



Muir Commercial Range

Established in 1968, Muir has become a dominant force in anchoring and mooring technology, recognised today as the anchoring system choice for a large variety and size of luxury motor and sail yachts.

Muir design and manufacture one of the largest ranges of anchoring and mooring systems for vessels up to 150 metres.

Muir have designed and produced anchoring and mooring equipment having set Industry Standards and benchmarks over many years. Continued investment in research and development, design and innovation, keeps Muir at the forefront of the yachting industry. The development of high power to weight ratio equipment with the combination of highly efficient planetary drive gears, medium to high pressure hydraulics, one, two or variable speed AC electric drives will achieve the ideal anchoring system to suit your vessel.

Muir surpass or meet the world's most stringent classification requirements including ABS, LRS, DNV, BV, NKK, GL, CCS, RINA, RRR, RMSR and comply with MCA and USL codes.

Muir running gear is available in polished 316L stainless steel, manganese bronze, chromed bronze and aluminium bronze.

316L polished stainless steel anchor windlasses and mooring capstans of all sizes are being manufactured in larger volumes today resulting in increased affordability.

A Muir anchoring system provides long term reliability, durability and dependability.



Muir Recreational Range

Selecting the appropriate windlass and ground tackle for your vessel and application ensures efficient deployment and retrieval of your anchor irrespective of anchoring or weather conditions. An undersized windlass may well compromise the safety of your vessel and crew. Choosing the right one should prevent costly repairs and damage.

When selecting a windlass there are a number of factors that need to be considered: vessel type, length and displacement, anchor and chain size, windage and the anchoring environment.

A windlass is often exposed to harsh elements therefore it is important to consider the materials and components it is manufactured from. Muir windlasses incorporate high quality components including chromed bronze and high quality marine grade 316 Stainless Steel running gear, stainless steel drive shafts and marine coated alloy housings, to ensure strength, durability and long term usage.

A powered windlass with some form of manual operation or override is always a wise choice and ensures peace of mind that the anchor can be retrieved if power failed or in an emergency. The type and style of windlass you select will depend on the depth of the chain locker, the fore deck layout, power options and personal preference.



Muir products are sold, serviced and supported worldwide.



AUSTRALIA • EUROPE • USA • ASIA • PACIFIC • AFRICA

Copyright notice and disclaimer

Copyright in this publication is owned by Muir Engineering Group Pty. Ltd.
Information in this publication is intended for general information only and does not constitute professional advice and should not be relied upon as such.
No representation or warranty is made as to the accuracy, reliability or completeness of any information in this publication.
Readers should make their own enquiries and reach to the nearest distributor before acting on or relying upon any of the information provided.
Images used within this publication remain the property of the copyright holders.

Cover and opposite page images supplied courtesy of Moonen Yachts
Back cover image supplied courtesy of Amels Yachts

Muir reserves the right to alter specifications without notice. All rights reserved. While all due care and attention has been taken in the preparation of this catalogue no responsibility shall be taken for errors or omissions.

THIS CATALOGUE SHOULD NOT BE USED FOR INSTALLATION PURPOSES
Any reference to MUIR or MUIR'S in this catalogue implies MUIR ENGINEERING GROUP PTY. LTD.
©2024 Muir Engineering Group Pty. Ltd.



SCAN FOR YOUR
LOCAL MUIR



The Muir Quality Management System is certified as being in conformity with ISO9001.



Head Office

100 Browns Road, Kingston
Tasmania, Australia 7050

T +61 (0) 3 6229 0600

F +61 (0) 3 6229 7030

E sales@muir.com.au

Queensland Branch

15/75 Waterway Dve, Coomera
Queensland, Australia 4209

T +61 (0) 7 5555 2222

New South Wales Branch

Unit D6, 1 Campbell Pde, Manly Vale
New South Wales, Australia 2093

T +61 (0) 2 9949 4084



Since 1968.
Built to last.

Image supplied courtesy of Amels Yachts



muir.com.au